

# SACAGAWEA DESIGNS

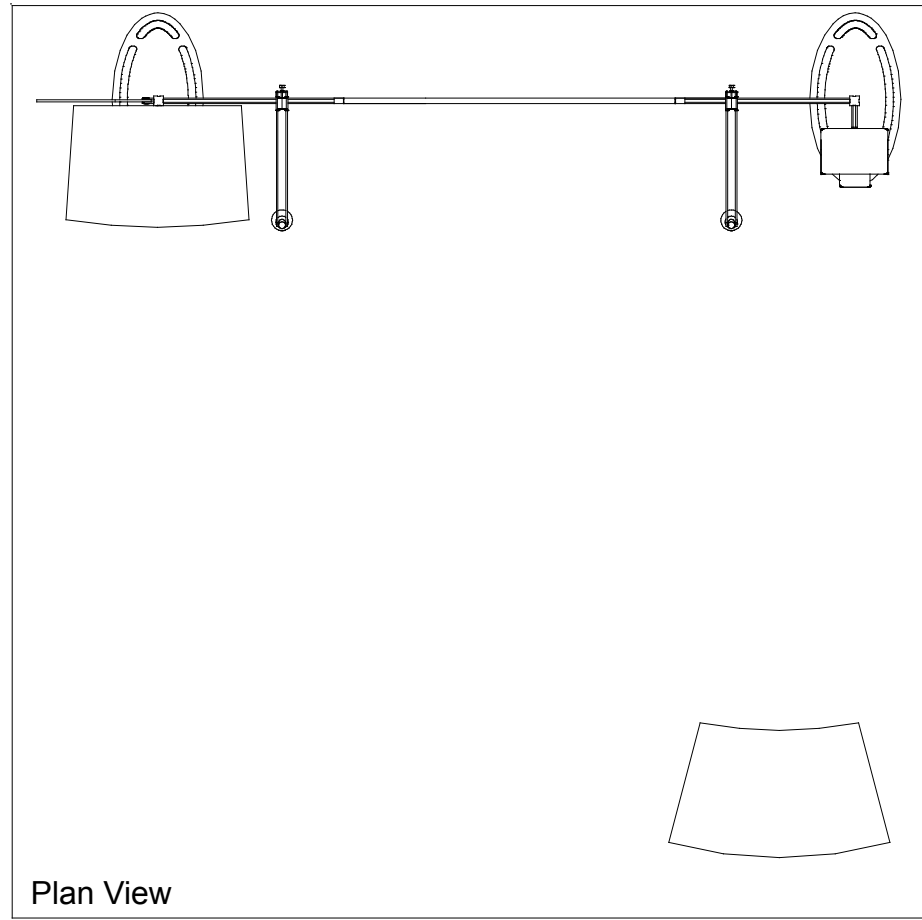

10'

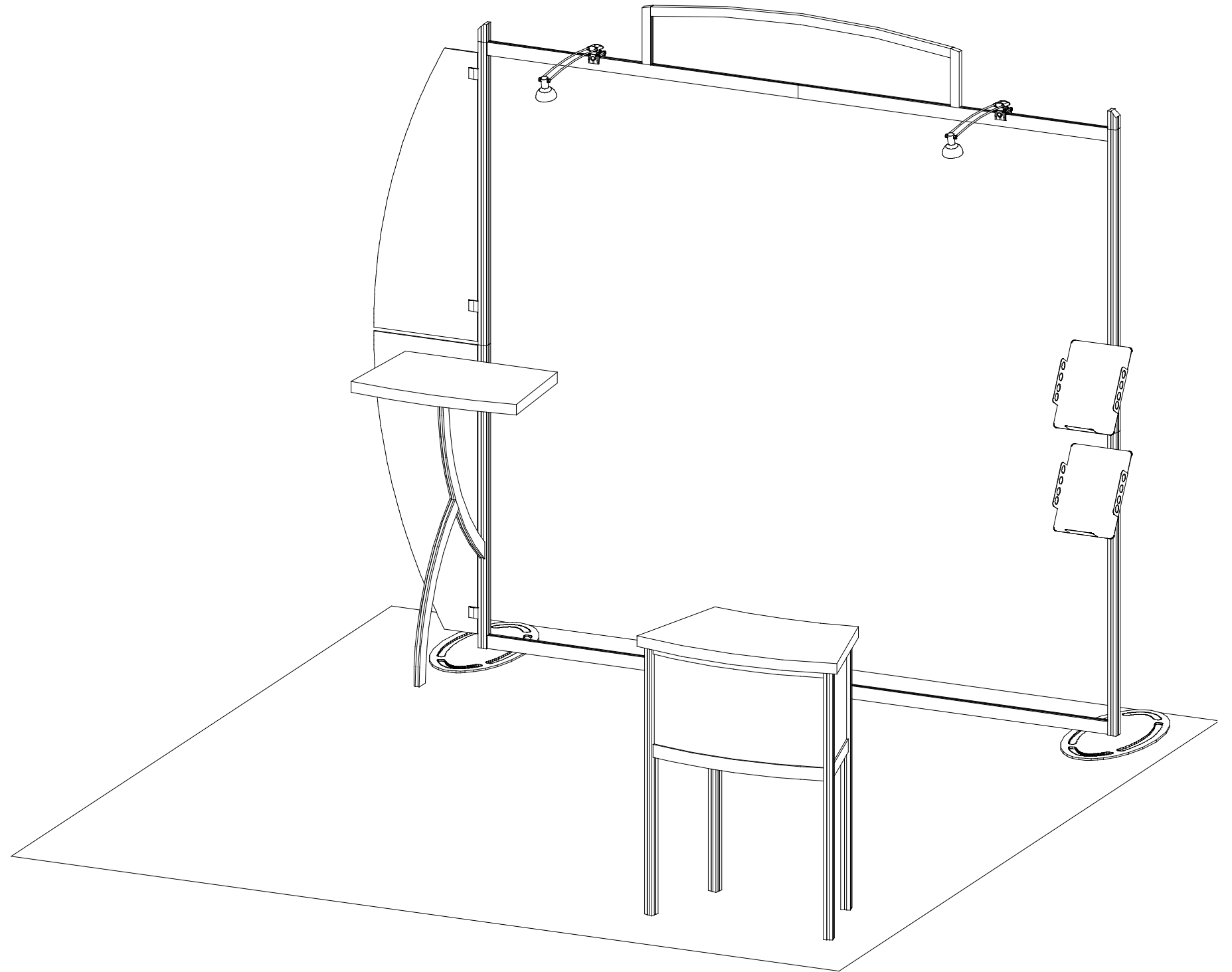

WHEN DISASSEMBLING ALUMINUM EXTRUSION, TIGHTEN ALL SETSCREWS AND LOCKS TO PREVENT LOSS DURING SHIPPING

# SACAGAWEA DESIGNS

## Using Your Set-up Instructions:

The Visionary Designs Set-up Instructions for Sacagawea displays are created specifically for your configuration. They are laid out sequentially, including an exploded view of the entire display and a logical series of detailed steps for assembly. We encourage you to study the instructions **before** attempting to assemble your exhibit.

### THIS IS VERY IMPORTANT!

Each page reminds you to tighten the setscrews after disassembling your exhibit to prevent loss of the locks and setscrews (see below in red).

## Cleaning & Packing Your Display:

- 1) Use care when cleaning aluminum extrusions or acrylic inserts. Use only non-abrasive cleaners.
- 2) When cleaning laminate inserts or counter tops, use mild cleansers and a soft material such as cotton.
- 3) Keep all display components away from extreme heat and long exposure to sunlight to avoid warping and fading.
- 4) Retain all packing materials. It will make re-packing much easier and will reduce the likelihood of shipping damage.

Hex Key Tool



Most visionary design exhibits can be assembled with the supplied Hex Key Tool. Occasionally, a flat head screwdriver may be required.

Typical Connection



**Detail A:** Most horizontal extrusion connections have a patented expandable lock. This lock inserts into the groove of an opposing extrusion. Tightening the lock with the Hex Key Tool expands the lock and creates a strong positive connection.

Typical Connection

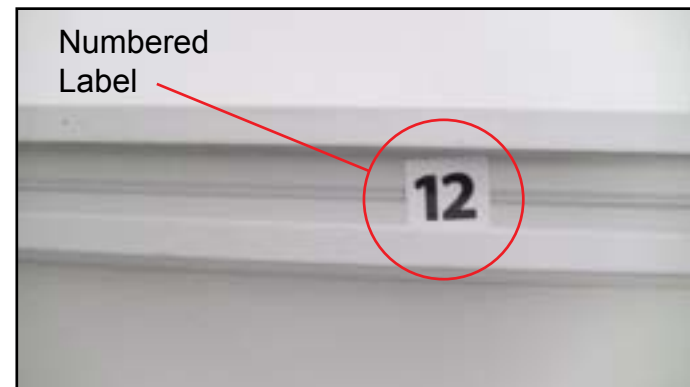

**Detail B:** Each extrusion contains a numbered label that corresponds to set-up instructions. The label is located within a groove of the extrusion (when possible). Visionary Design labels contain Black numbers unless otherwise specified.

Horizontal Connection

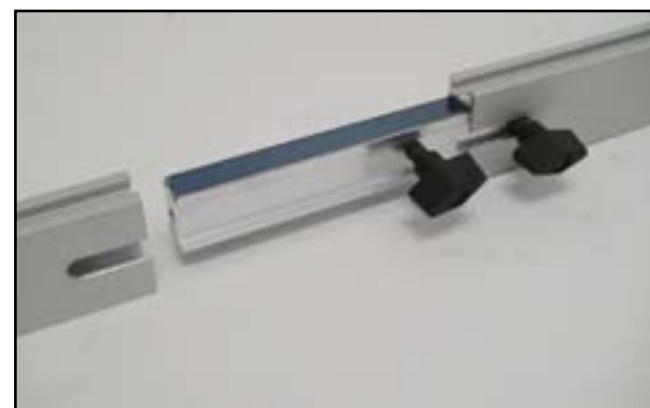

**Detail C:** A rectangular connection bar with plastic T Knobs is inserted between two horizontal extrusions joined end-to-end. Turn the knobs clockwise to tighten.

Do Not Overtighten.

Base Plate Connection



**Detail D:** Attach vertical extrusions to base plates with supplied bolts inserted through the hole in the plate. Be careful not to strip the thread.

Vertical Connection



**Detail E:** A square connection bar with plastic T Knobs is inserted between two vertical extrusions joined end-to-end. Turn the knobs clockwise to tighten.

Do Not Overtighten.

Corner Connection



**Detail F:** Plastic Star Knobs are used to tighten locks where horizontal extrusions connect with vertical extrusions. Turn the knobs clockwise to tighten. Turn counter-clockwise to loosen, but do not remove knob.

Do Not Overtighten.

**WHEN DISASSEMBLING ALUMINUM EXTRUSION, TIGHTEN ALL SETSCREWS AND LOCKS TO PREVENT LOSS DURING SHIPPING**

Item	Qty.	Description
1	2	Base Plate
2a/2b	1/1	42" Vertical Extrusion
3a/3b	1/1	42" Vertical Extrusion
4a/4b	1/1	45" Horizontal Extrusion
5a/5b	1/1	45" Horizontal Extrusion
6a/6b	1/1	2.5" Angle-Cut Vertical

Steps:

- 1) Attach base plates [1] to lower verticals [2a,3a] with bolts.
- 2) Connect upper verticals [2b,3b] to lower verticals [2a,3a] with connection bars [b].
- 3) Connect horizontals [4a,4b] and [5a,5b] with connection bars [a].
- 4) Connect vertical assemblies [2a/2b,3a/3b] with horizontal assemblies [4a/4b,5a/5b] as shown.
- 5) Connect angled verticals [6a,6b] to upper verticals as shown.
- 6) Attach graphics to **velcro** on back side of frame.

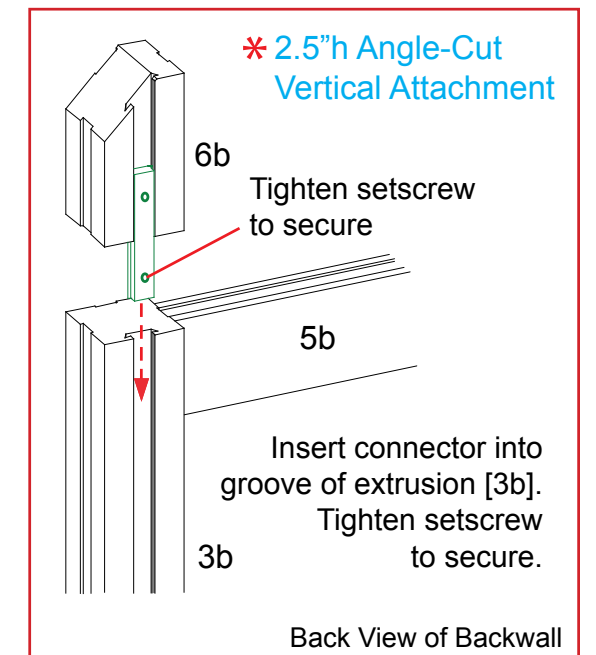
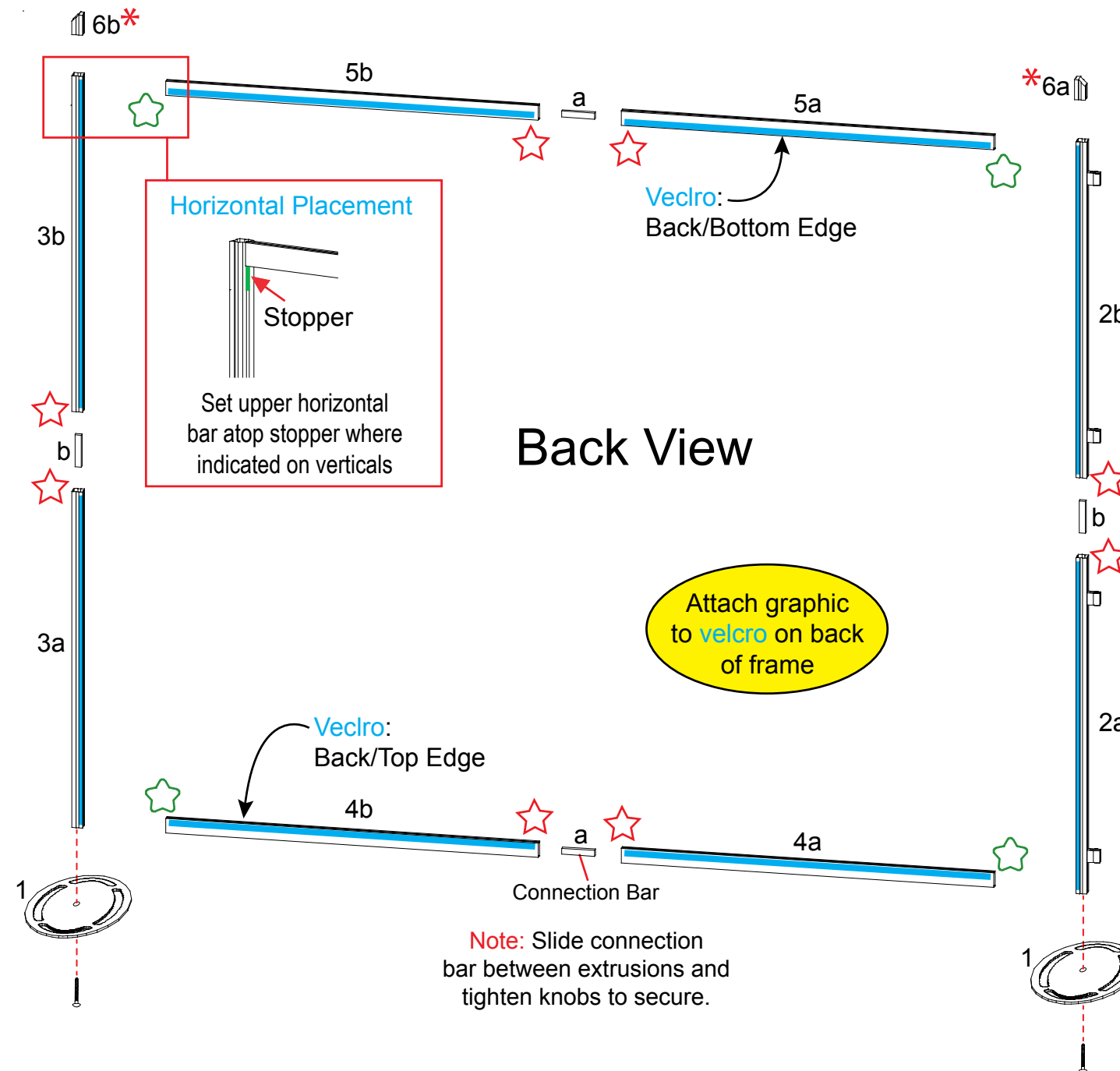
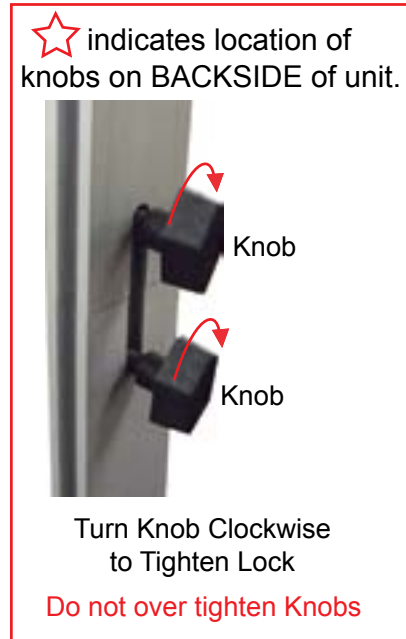
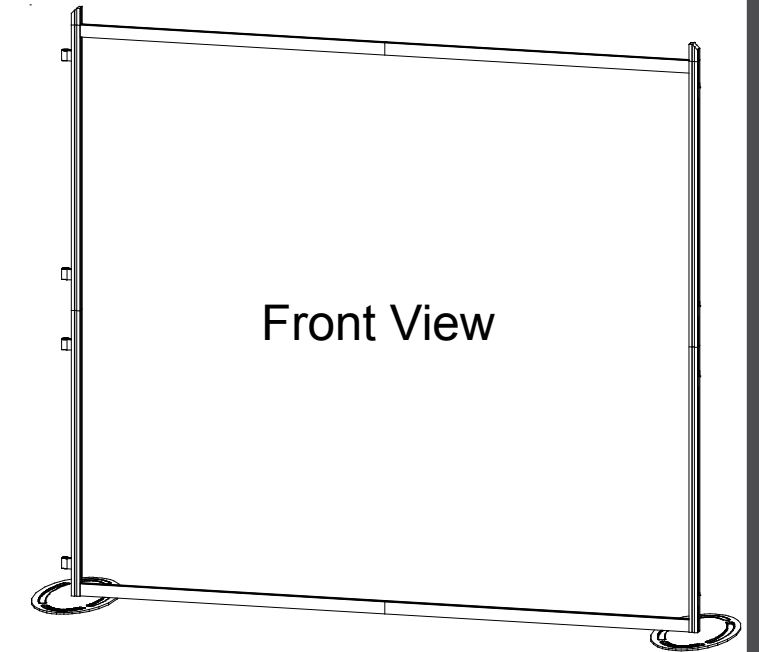

**WHEN DISASSEMBLING ALUMINUM EXTRUSION, TIGHTEN ALL SETSCREWS AND LOCKS TO PREVENT LOSS DURING SHIPPING**

Steps:

- 1) Attach lights as indicated.
- 2) Attach assembled counter support [10/11] to vertical where indicated.
- 3) Attach support leg [10a] to counter support [10/11].
- 4) Attach flange plate [11a] to top of curved extrusion [10] as shown.
- 5) Attach counter top to support, see [counter top attachment](#) detail.
- 6) Attach wings to A10 clamps as shown.
- 7) Attach monitor mount to backwall as shown.
- 8) Attach pamphlet trays to backwall frame.

Item	Qty.	Description
10	1	30.2" Curved Extrusion
10a	1	Leg Support
11	1	12.184"w Horizontal Extrusion
11a	1	Flange Plate

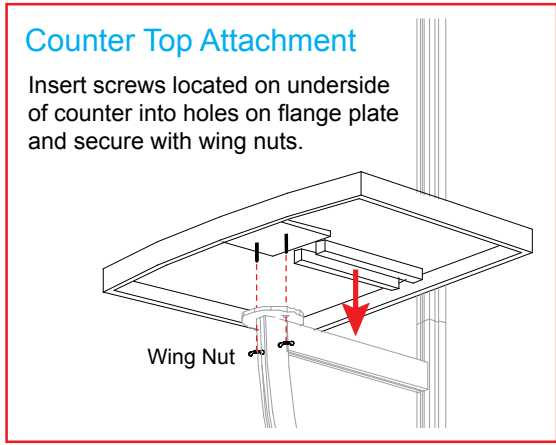
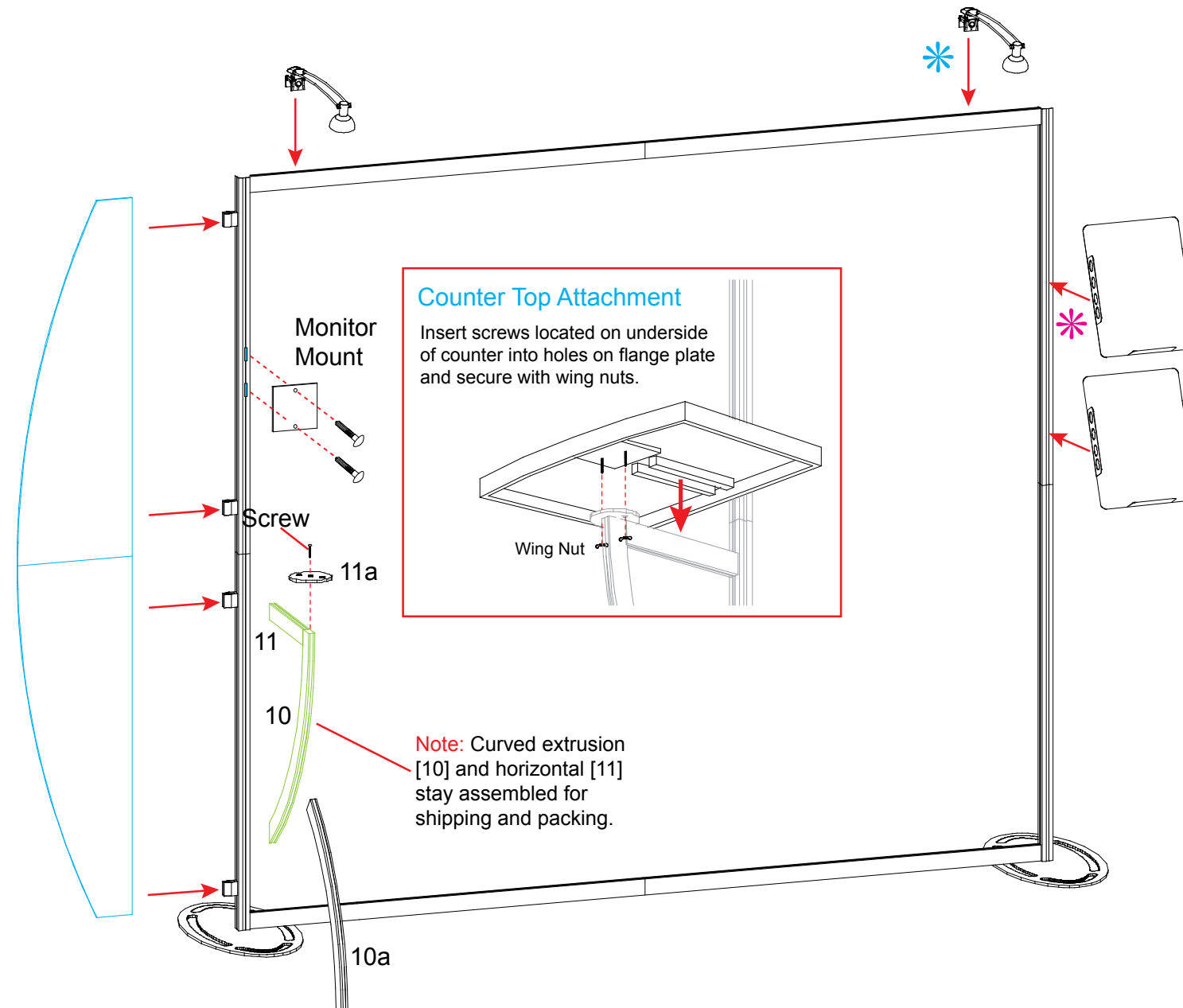
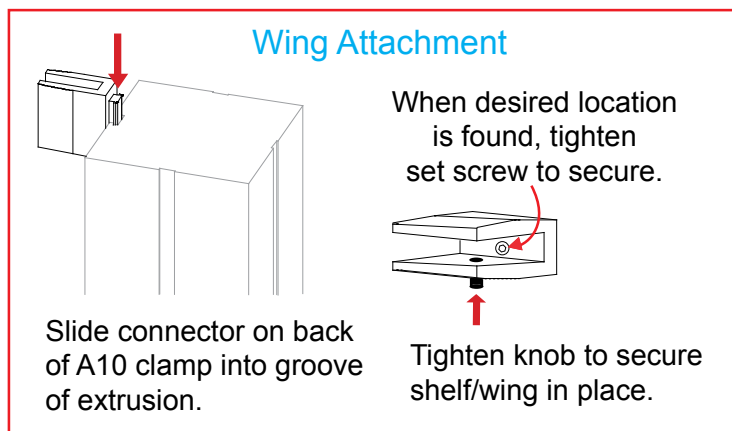
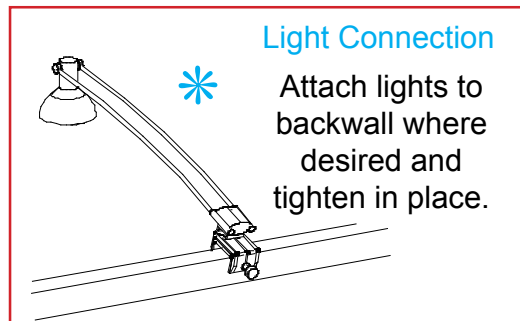

**Note:** Curved extrusion [10] and horizontal [11] stay assembled for shipping and packing.

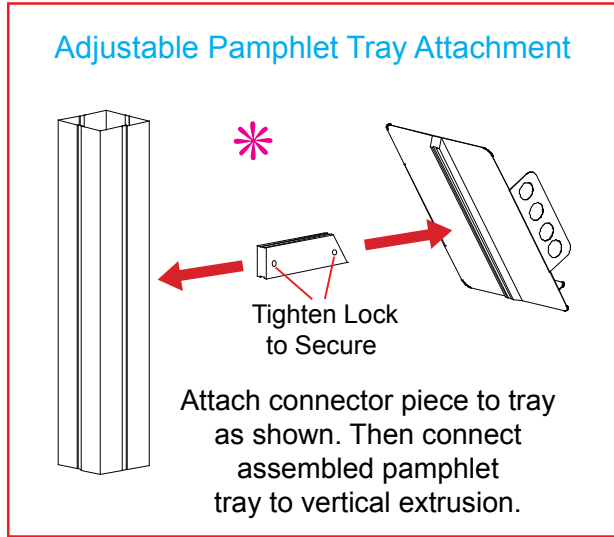
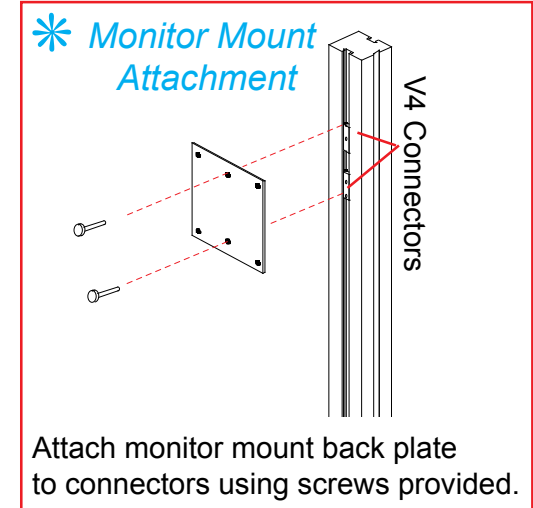

**WHEN DISASSEMBLING ALUMINUM EXTRUSION, TIGHTEN ALL SETSCREWS AND LOCKS TO PREVENT LOSS DURING SHIPPING**

866.652.2100

Part Number	Qty	Description
12	4	38" h Vertical Extrusion
13/13a	2/2	12" w Horizontal Extrusion
14	2	25" w Horizontal Extrusion

Steps

- 1) Attach horizontal extrusions [13 and 13a] between vertical extrusions [12], placing inserts between horizontals.
- 2) Attach curved horizontal extrusions [14] between vertical extrusions [12], placing insert between curved horizontals.
- 3) Place shelf atop lip of extrusions.
- 4) Set counter top atop assembled base.

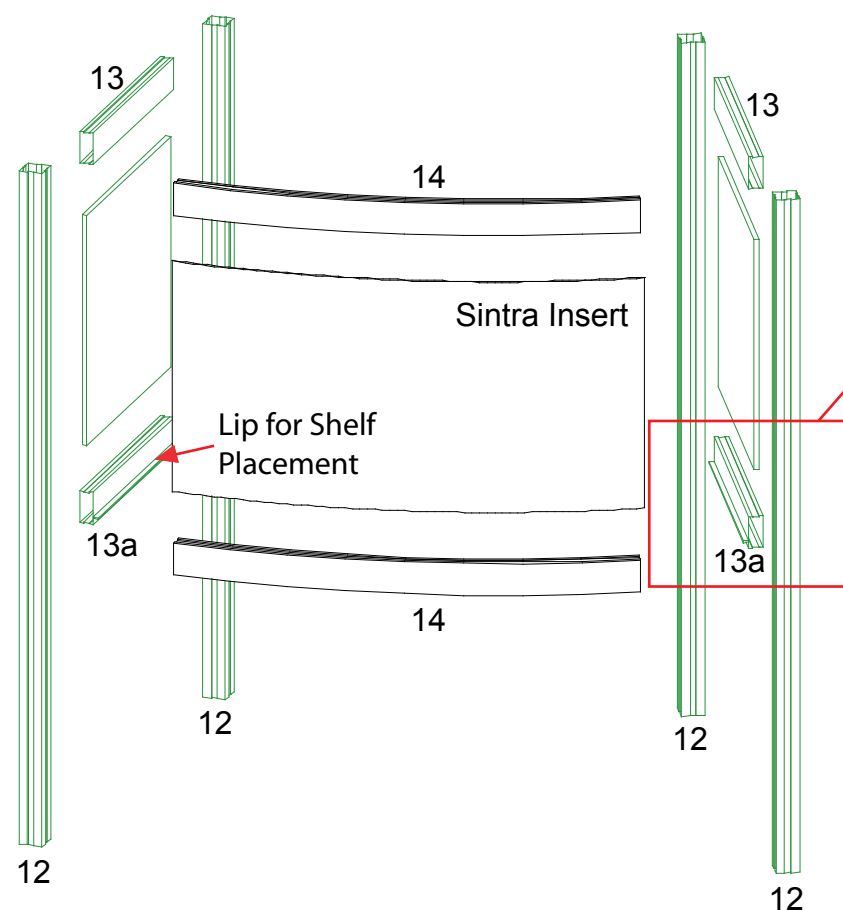
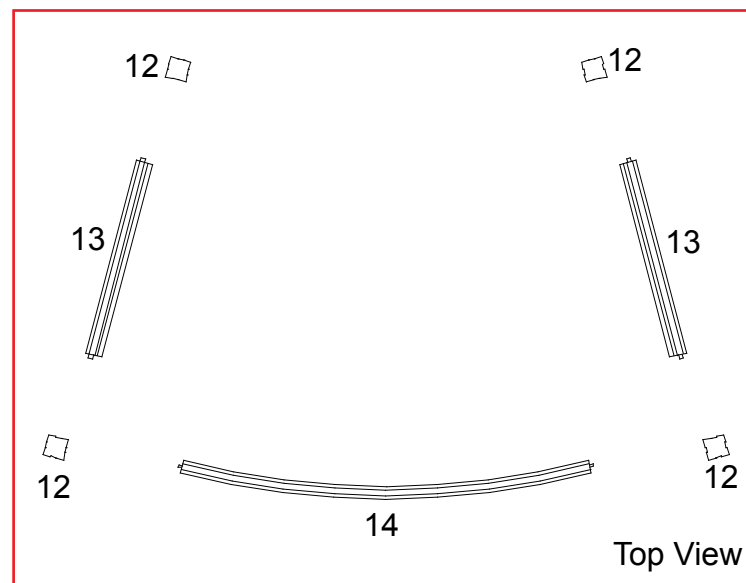

**Extrusion Details:**  
Extrusions 13a have a lip for the floor to rest upon.

**Note:** Pedestal sides must stay assembled when shipping

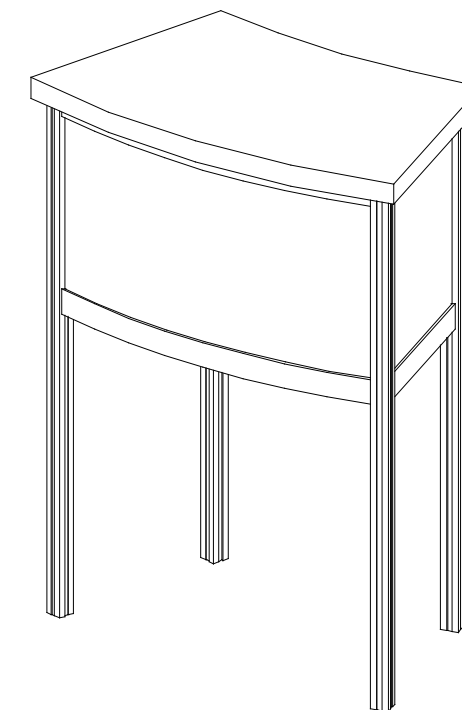
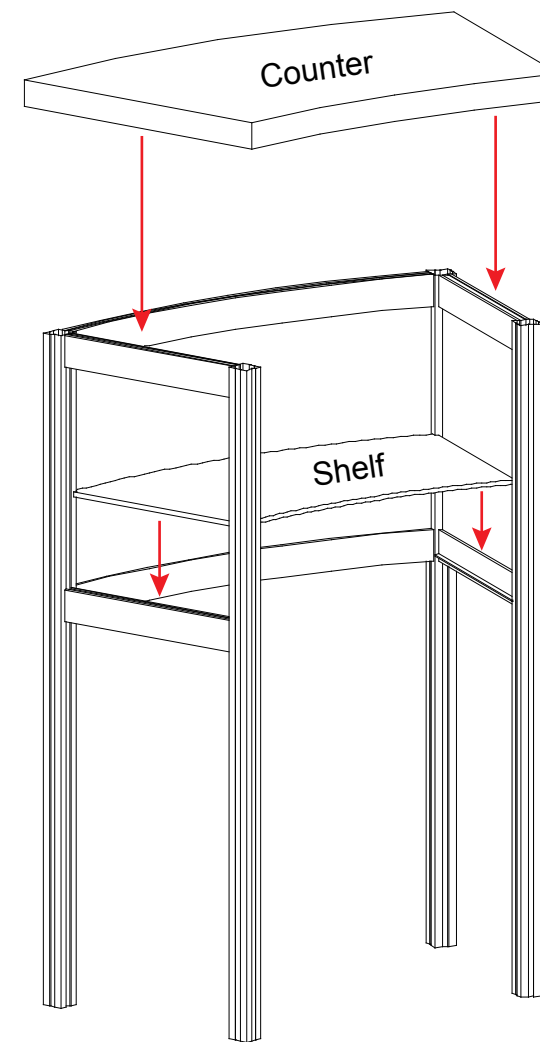

**WHEN DISASSEMBLING ALUMINUM EXTRUSION, TIGHTEN ALL SETSCREWS AND LOCKS TO PREVENT LOSS DURING SHIPPING**

Top View of Each Level

Backwall Components

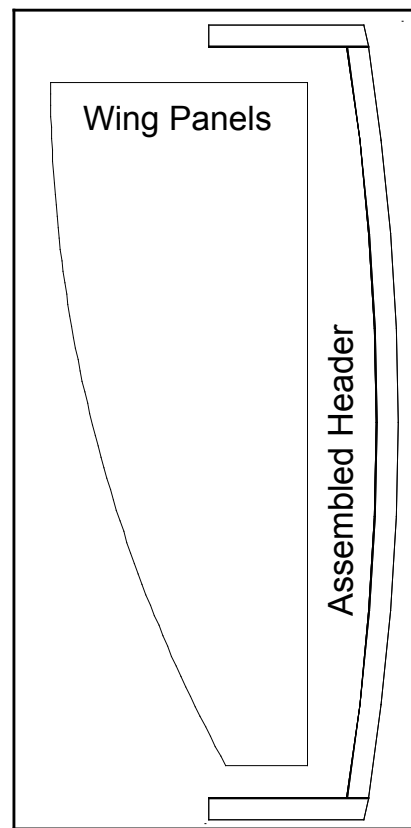

Level 1

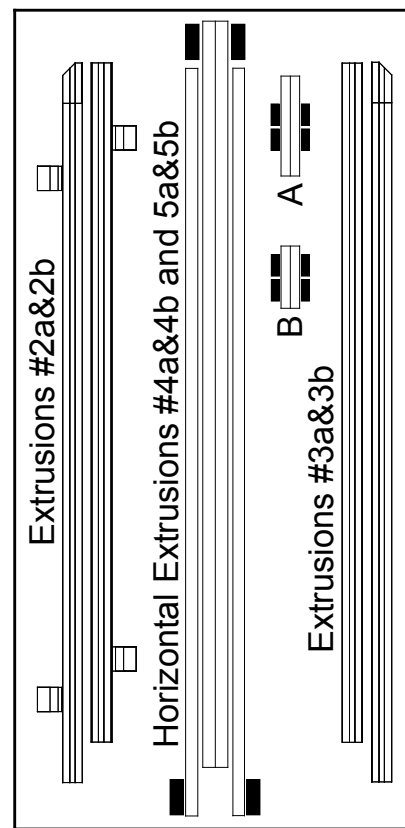

Level 2

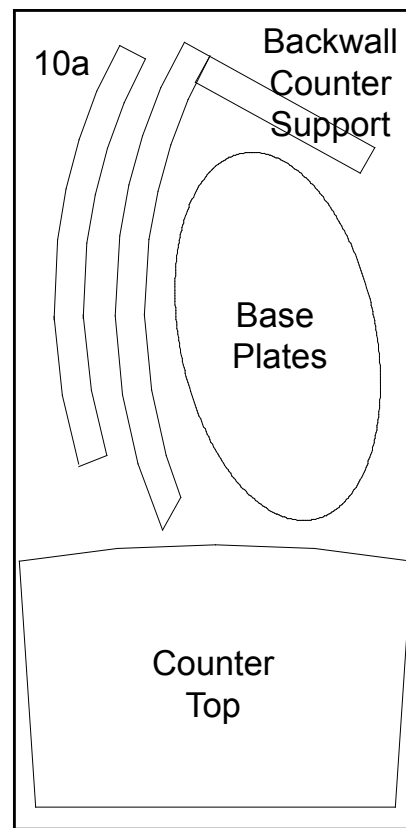

Level 3

- Halogen Lights
- Graphics
- Literature Pockets
- Setup Hardware

WHEN DISASSEMBLING ALUMINUM EXTRUSION, TIGHTEN ALL SETSCREWS AND LOCKS TO PREVENT LOSS DURING SHIPPING

Top View of Each Level

Pedestal Components

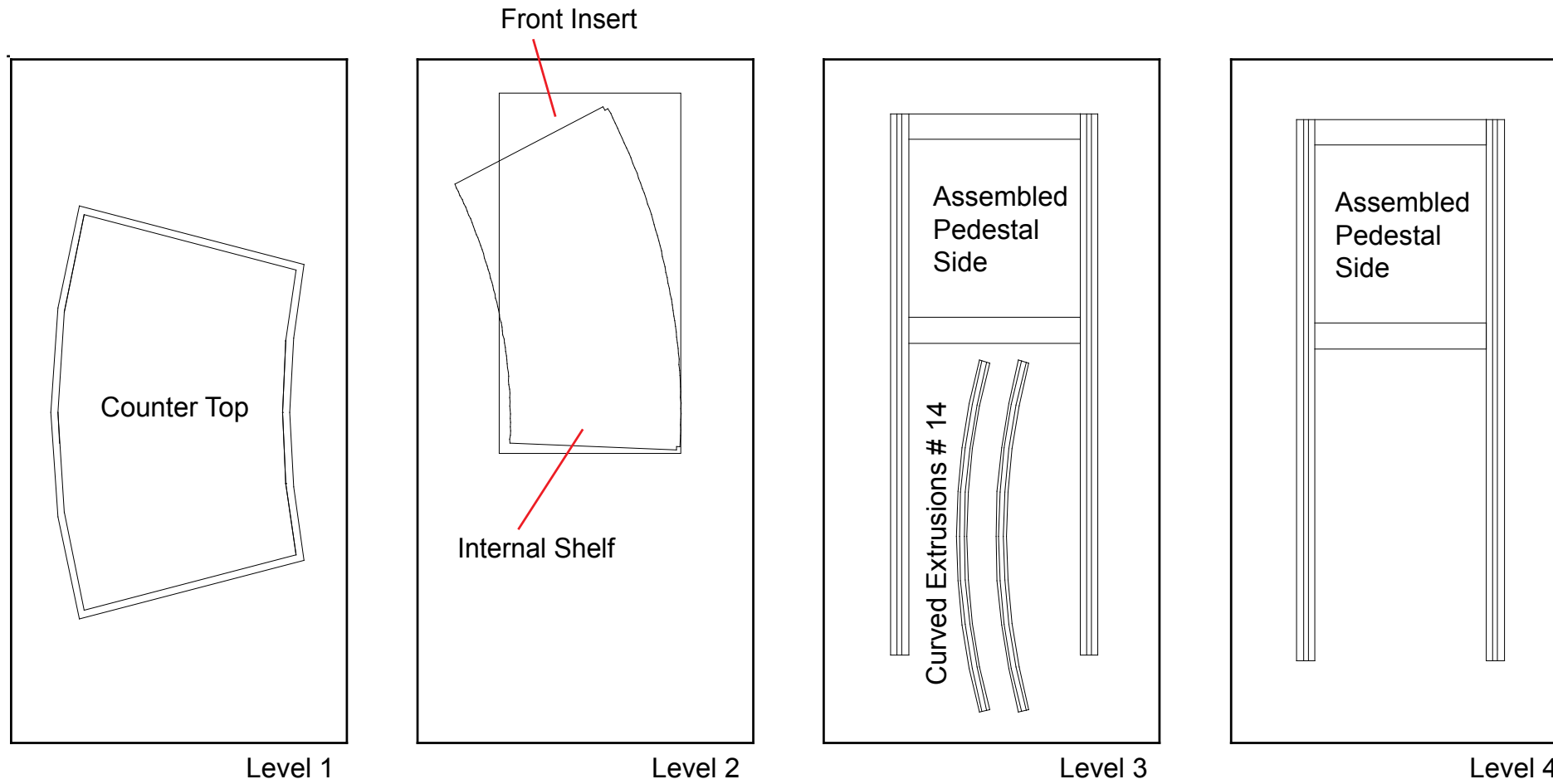

WHEN DISASSEMBLING ALUMINUM EXTRUSION, TIGHTEN ALL SETSCREWS AND LOCKS TO PREVENT LOSS DURING SHIPPING