

WHEN DISASSEMBLING ALUMINUM EXTRUSION, TIGHTEN ALL SETSCREWS AND LOCKS TO PREVENT LOSS DURING SHIPPING

# visionary™ IDESIGNS

## Using Your Setup Instructions

The Visionary Designs Setup Instructions are created specifically for your configuration. They are laid out sequentially, including an exploded view of the entire display, and then a logical series of detailed steps to assemble the main structure and components. We encourage you to study the instructions **before** attempting to assemble your exhibit.

Each page reminds you to tighten the setscrews after disassembling your exhibit to prevent loss of the locks and setscrews (see below in RED). This is **VERY IMPORTANT**.

## Cleaning and Packing Your Display

- 1) Use care when cleaning aluminum extrusion or acrylic inserts. Use only non-abrasive cleaners.
- 2) When cleaning laminate inserts or countertops, use mild cleansers and a soft material such as cotton.
- 3) Keep all display components away from extreme heat and long exposure to sunlight to avoid warping and fading.
- 4) Retain all packing material. It will make re-packing much easier and will reduce the likelihood of shipping damage.



**The Tool**

Most Visionary Designs exhibits can be assembled with the supplied Hex Key Tool. Occasionally, a flat head screwdriver may be required.



**Typical Connection**

Most horizontal extrusion connections have a patented expandable lock. This lock inserts into the groove of an opposing extrusion. Tightening the lock with the Hex Key Tool expands the lock and creates a strong positive connection.



**Typical Connection (cont'd)**



**Detail B**

**Numbered Label**

Each extrusion contains a numbered label which corresponds with setup instructions. The label is located within a groove of the extrusion (when possible). With Visionary Designs the labels contain Black numbers unless otherwise specified.



**Detail C**

**Horizontal Inline Connection** (remove only one setscrew)

Remove only (1) setscrew when disassembling. Replace setscrew in extrusion after assembling it. Before packing, replace setscrew in extrusion to avoid losing it.

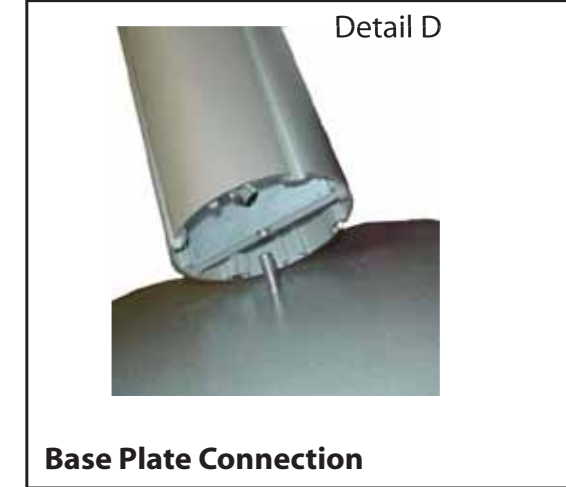

**Detail D**

**Base Plate Connection**

Attach base plate to round or square vertical extrusion using the bolt provided. Be careful not to strip the threads.

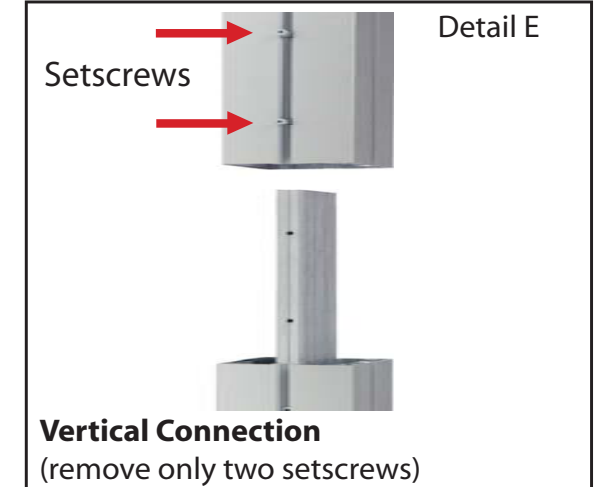

**Detail E**

**Vertical Connection**  
(remove only two setscrews)

When vertical extrusions are packed in portable cases rather than crates or tubs, they must be broken down into smaller sections which then require assembly.

Remove only (2) setscrews when disassembling. Replace setscrews in extrusion after assembling it. Before packing, replace setscrews in extrusion to avoid losing them.

**WHEN DISASSEMBLING ALUMINUM EXTRUSION, TIGHTEN ALL SETSCREWS AND LOCKS TO PREVENT LOSS DURING SHIPPING**

866.652.2100

Item	Qty.	Description
1	8	96"h Vertical Extrusion
2	4	18"w Horizontal Extrusion
3	4	30.5"w Horizontal Extrusion
3a	2	5.75"w Horizontal Extrusion
3b	2	5.5"w Horizontal Extrusion
4	4	88.834"h Vertical Extrusion
5/5a	2/2	Gusset Plate
6	2	13.875"w Horizontal Extrusion
7	2	3"w Horizontal Extrusion
8	2	12.125"w Horizontal Extrusion
9	2	4.625"w Horizontal Extrusion

Steps:

- 1) Set assembled towers on display floor, see illustration below for tower orientation.  
*Note:* Each tower must stay assembled when shipping in wood crate.
- 2) Attach gusset plates to bottom of left and right towers as indicated.

**\*\*Remove extrusions [7] before installing graphic frame to tower.**

**\*\*Remove extrusions [9] before installing graphic frame to tower.**

**A10 Clamp Attachment**

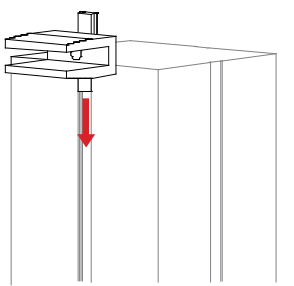

Slide connector on back of A10 clamp into groove of extrusion.

When desired location is found, tighten set screw to secure.

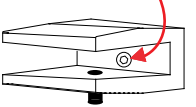

Tighten black plastic set screw to secure shelf in place.

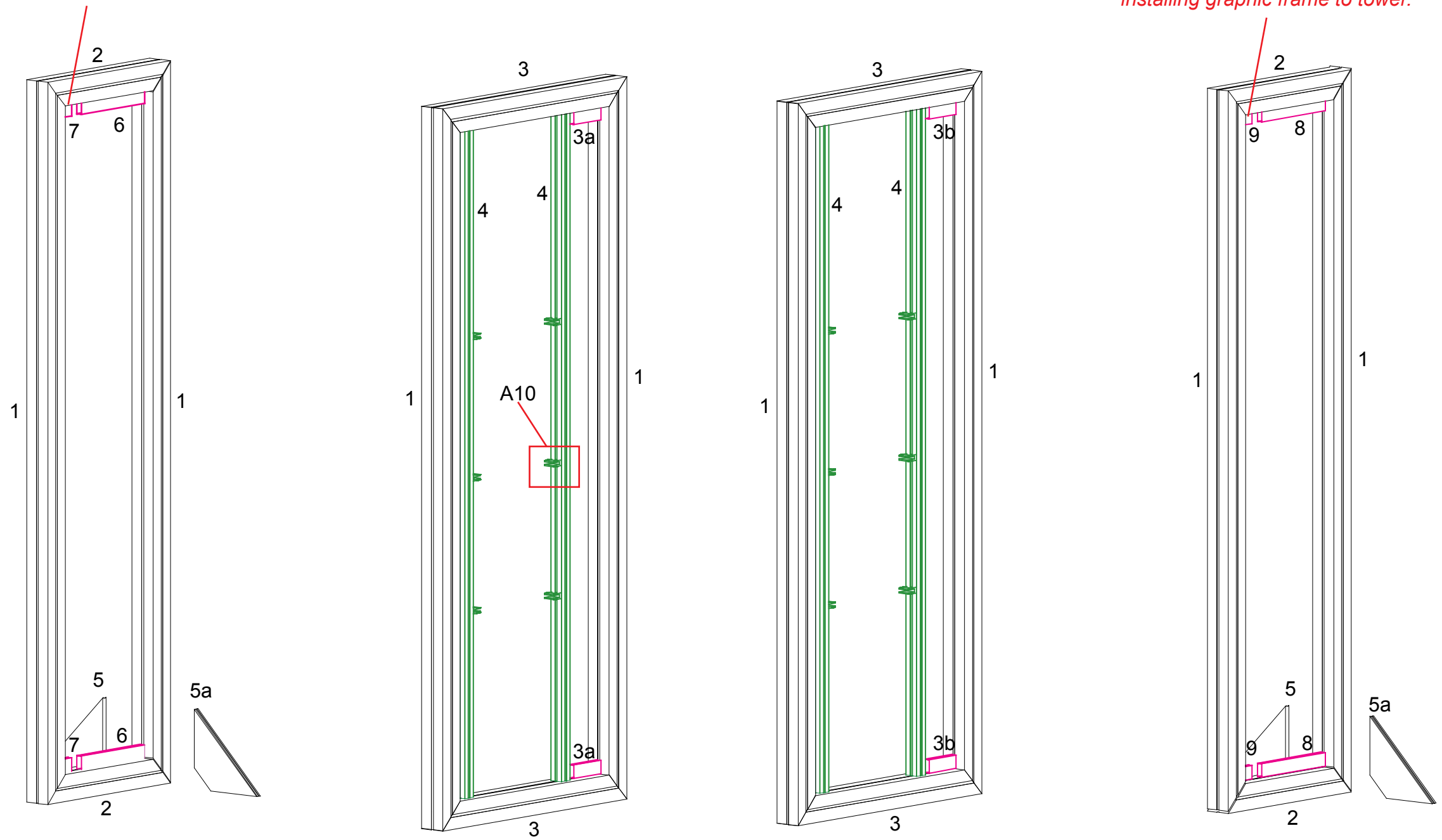

**WHEN DISASSEMBLING ALUMINUM EXTRUSION, TIGHTEN ALL SETSCREWS AND LOCKS TO PREVENT LOSS DURING SHIPPING**

866.652.2100

Item	Qty.	Description
10	2	18" w Horizontal Extrusions
10A	1	18" w Horizontal Extrusions: Monitor Mount Attachment Bar

Steps:

- 1) Connect center towers together using horizontal bars [10 and 10A], placing infill panel between horizontal bars.
- 2) Attach Plex shelves to A10 clamps, see Shelf Attachment.

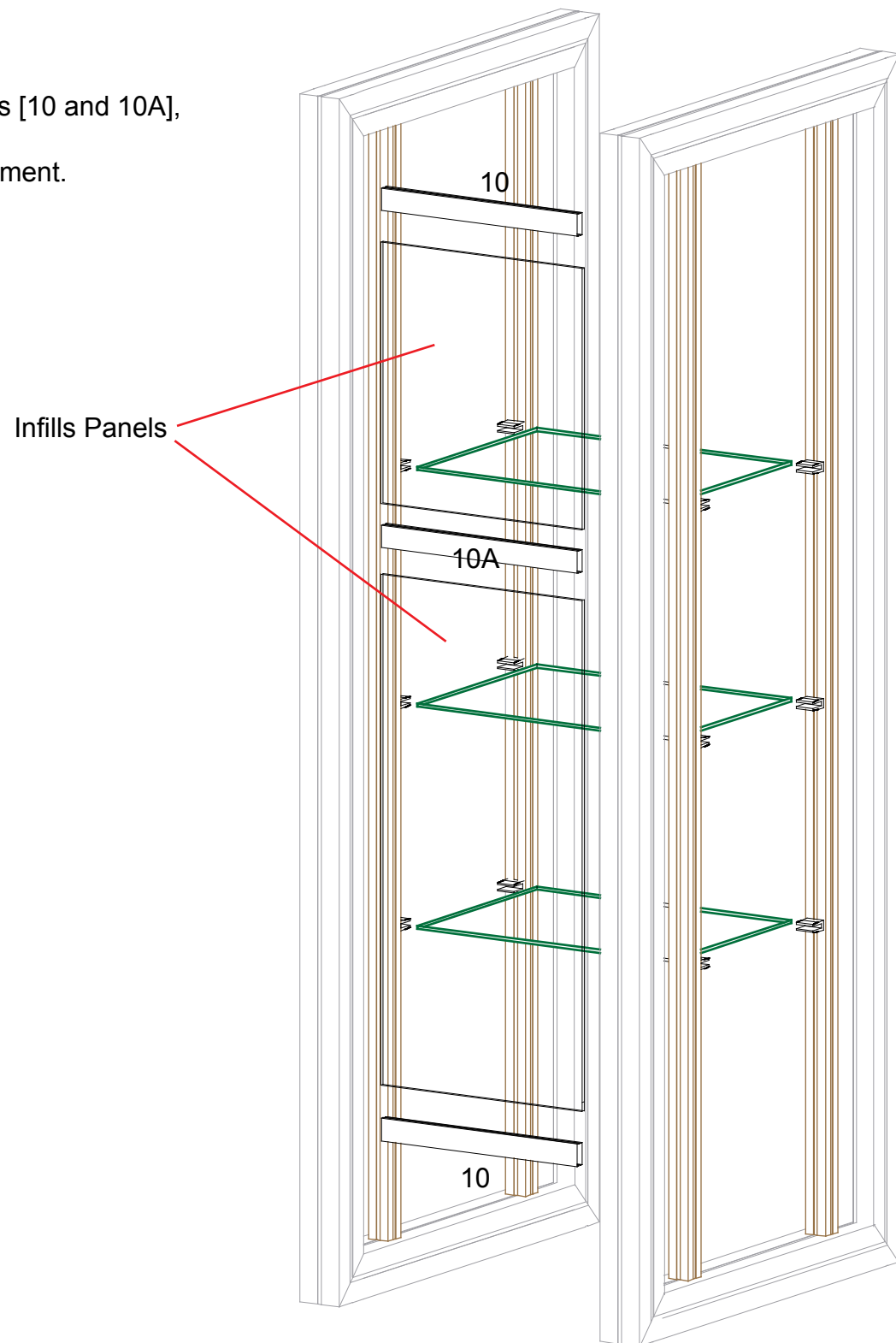

*Shelf Attachment*

A10  
A10  
Plex Shelf  
A10  
A10

---

*A10 Clamp Attachment*

Slide connector on back of A10 clamp into groove of extrusion.

When desired location is found, tighten set screw to secure.

Tighten black plastic set screw to secure shelf in place.

**WHEN DISASSEMBLING ALUMINUM EXTRUSION, TIGHTEN ALL SETSCREWS AND LOCKS TO PREVENT LOSS DURING SHIPPING**

866.652.2100

Item	Qty.	Description
11	1	14"w Horizontal Extrusion
12	1	90° Corner Extrusion
13	1	53.375"w Horizontal Extrusion
14	1	53.375"w Horizontal Extrusion
15	1	4.875"w Horizontal Extrusion
16	1	90° Corner Extrusion
17	1	71.1875"w Horizontal Extrusion

- Steps:
- 1) Connect horizontal pieces together to create stabilizing bars.
  - 2) Connect left and right towers to center tower using stabilizing bars as shown.

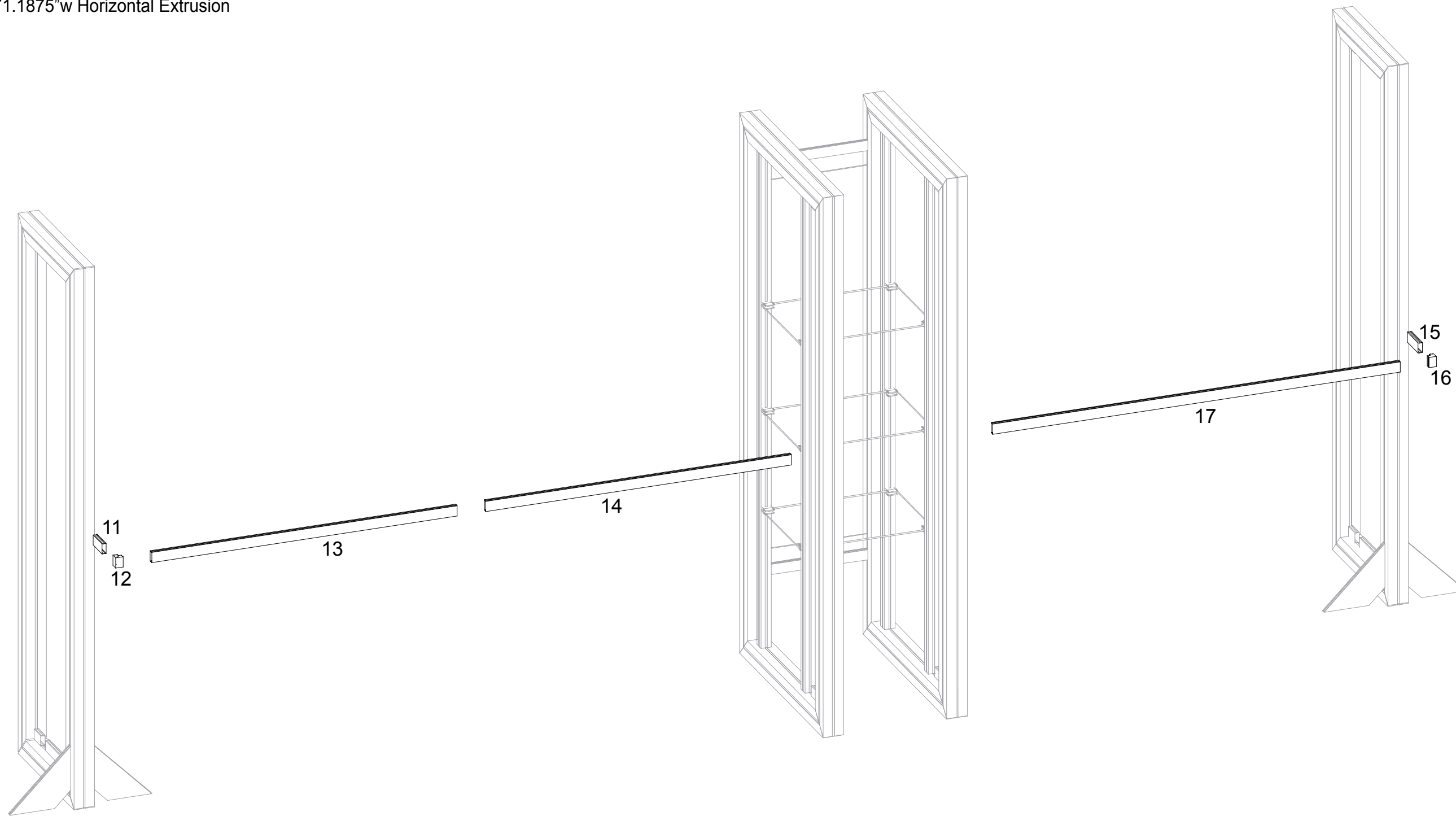

**WHEN DISASSEMBLING ALUMINUM EXTRUSION, TIGHTEN ALL SETSCREWS AND LOCKS TO PREVENT LOSS DURING SHIPPING**

866.652.2100



**Using Your Setup Instructions**

The Aero Overhead Sign Setup Instructions are created specifically for your configuration. They include an exploded view of the frame which is sequentially numbered. We encourage you to study the instructions before attempting to assemble your exhibit.

Connections are kept very simple: no tools. Everything assembles with push-button connectors and pre-connected horizontal sections.

**Cleaning and Packing Your Display**

- 1) Use care when cleaning aluminum extrusion or acrylic inserts. Use only non-abrasive cleaners.
- 2) Retain all packing material. It will make re-packing much easier and will reduce the likelihood of shipping damage.

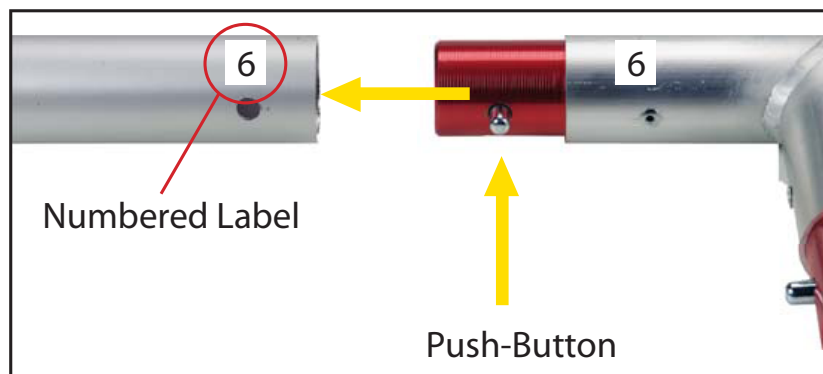

Connections are made by holding the button down and sliding the red tube into opposing tube until the connection is made. To disassemble push button and pull or twist extrusions apart.

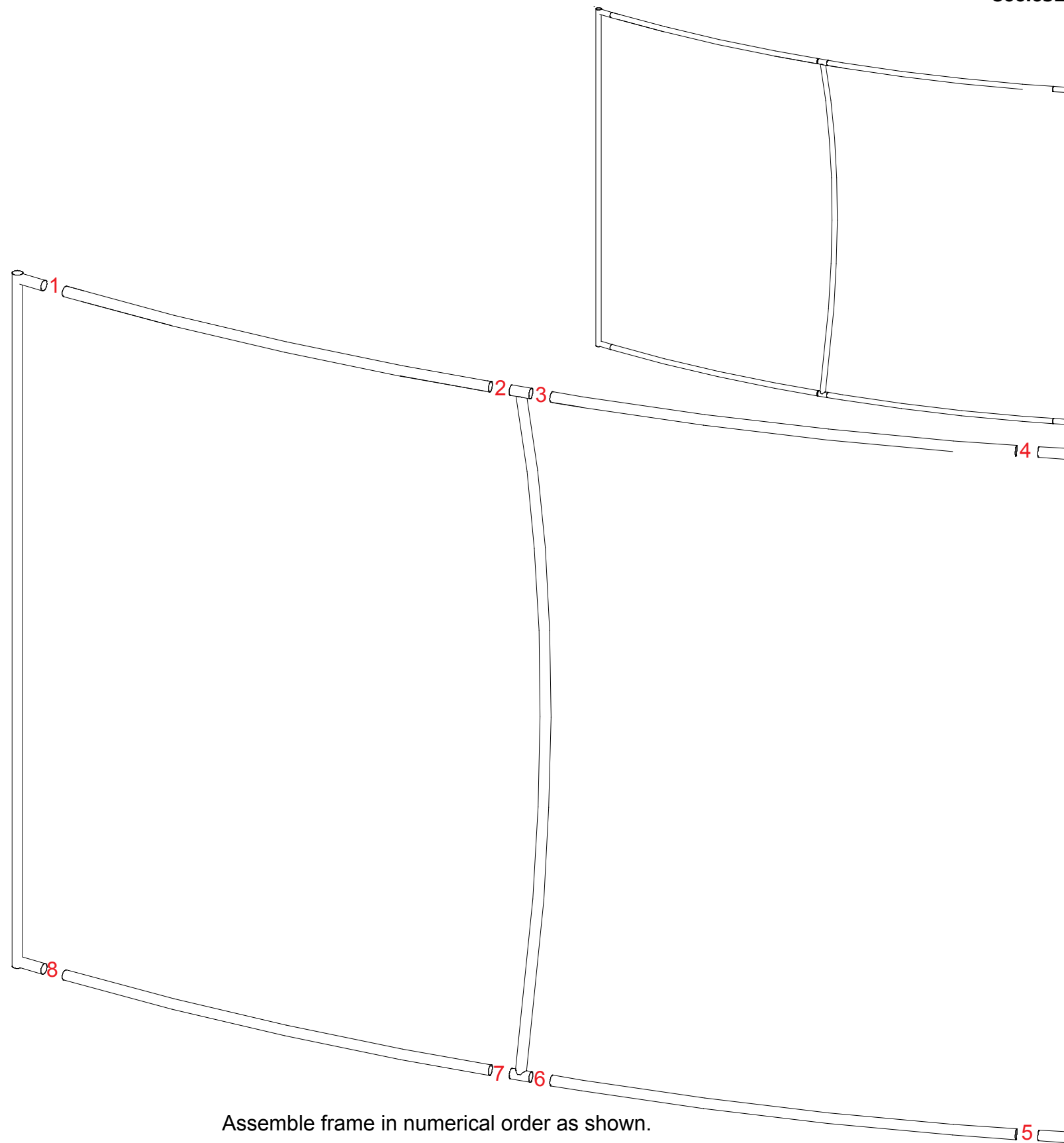
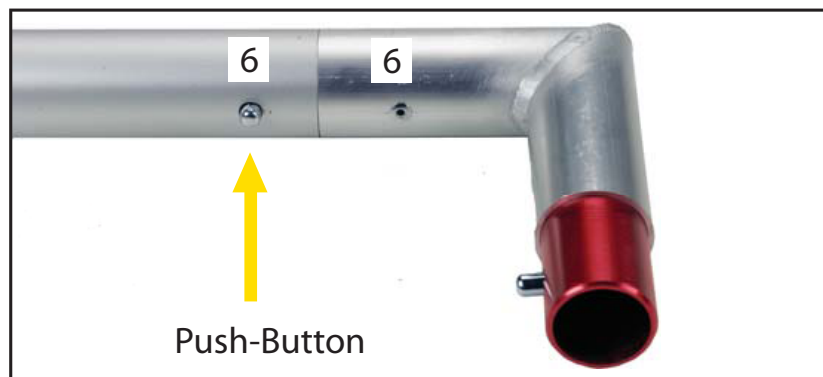

Assemble frame in numerical order as shown.

**WHEN DISASSEMBLING ALUMINUM EXTRUSION, TIGHTEN ALL SETSCREWS AND LOCKS TO PREVENT LOSS DURING SHIPPING**

866.652.2100



**Using Your Setup Instructions**

The Aero Overhead Sign Setup Instructions are created specifically for your configuration. They include an exploded view of the frame which is sequentially numbered. We encourage you to study the instructions before attempting to assemble your exhibit.

Connections are kept very simple: no tools. Everything assembles with push-button connectors and pre-connected horizontal sections.

**Cleaning and Packing Your Display**

- 1) Use care when cleaning aluminum extrusion or acrylic inserts. Use only non-abrasive cleaners.
- 2) Retain all packing material. It will make re-packing much easier and will reduce the likelihood of shipping damage.

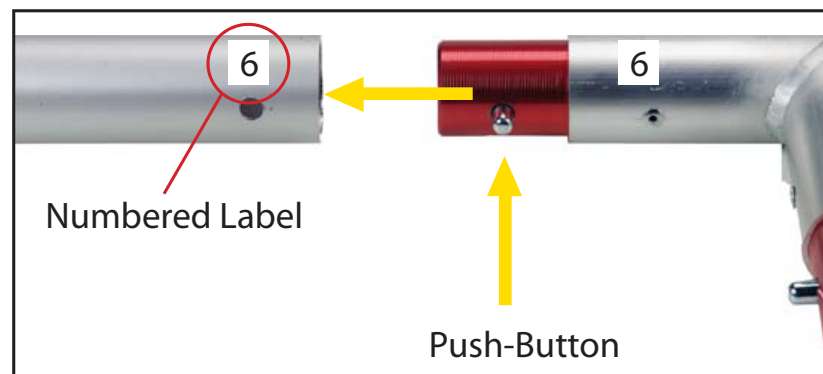

Connections are made by holding the button down and sliding the red tube into opposing tube until the connection is made. To disassemble push button and pull or twist extrusions apart.

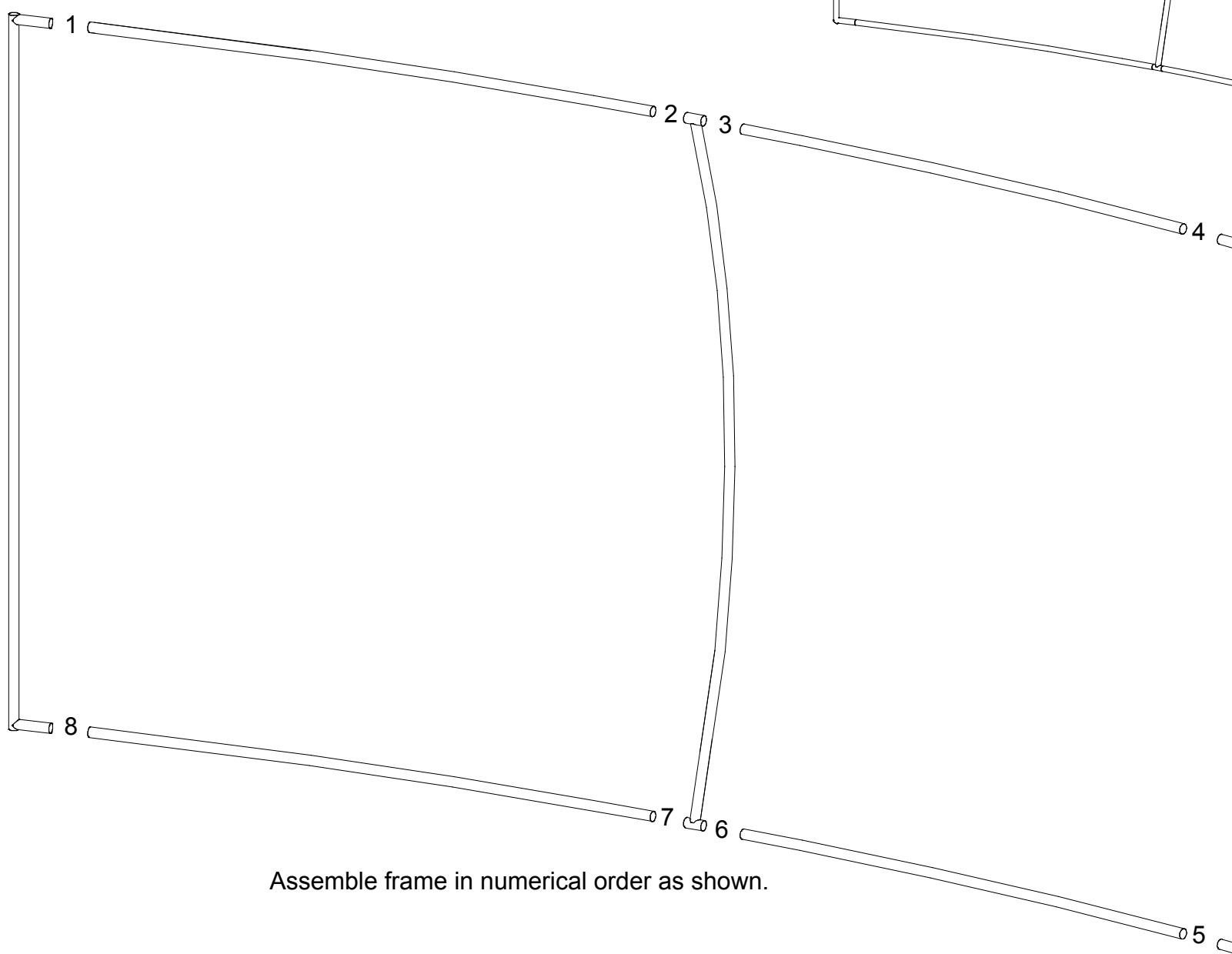
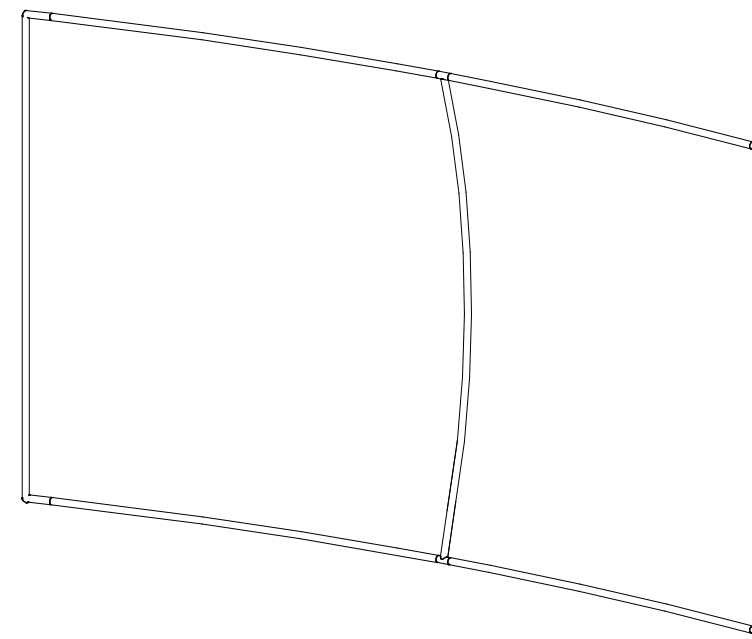
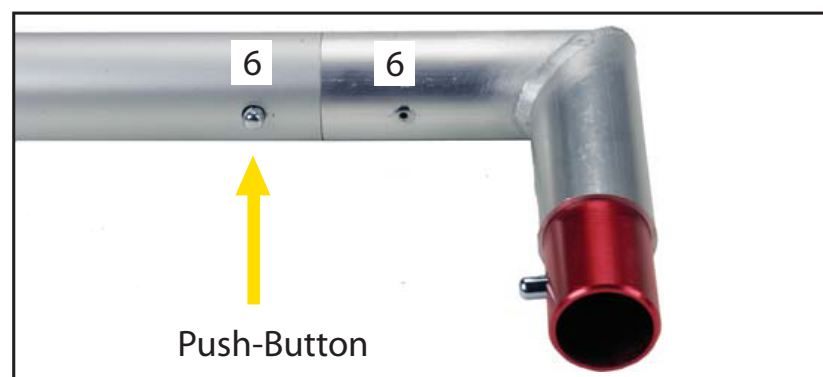

Assemble frame in numerical order as shown.

**WHEN DISASSEMBLING ALUMINUM EXTRUSION, TIGHTEN ALL SETSCREWS AND LOCKS TO PREVENT LOSS DURING SHIPPING**

866.652.2100

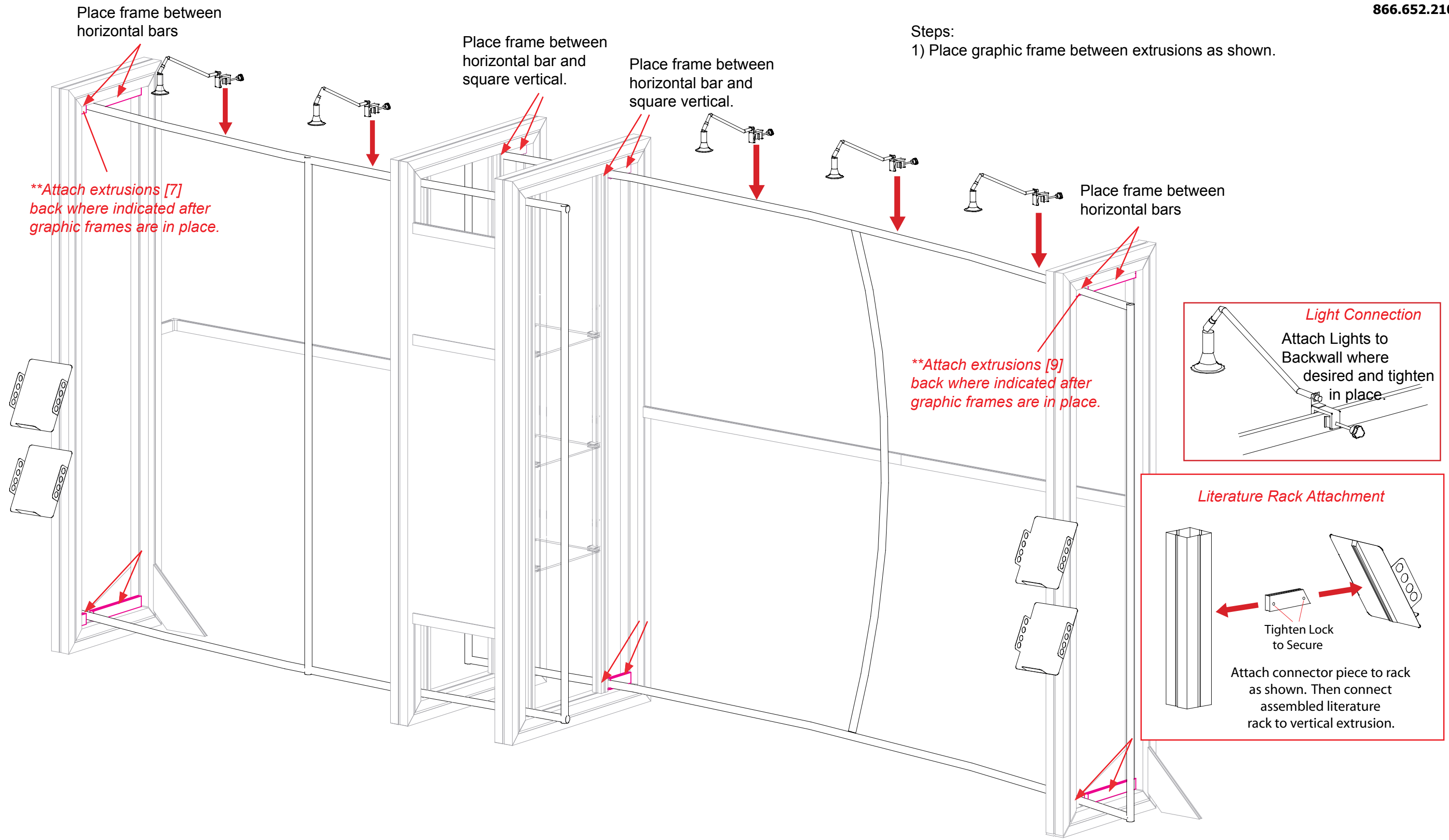

Steps:  
1) Place graphic frame between extrusions as shown.

**\*\*Attach extrusions [7] back where indicated after graphic frames are in place.**

**\*\*Attach extrusions [9] back where indicated after graphic frames are in place.**

**Light Connection**  
Attach Lights to Backwall where desired and tighten in place.

**Literature Rack Attachment**

Tighten Lock to Secure

Attach connector piece to rack as shown. Then connect assembled literature rack to vertical extrusion.

**WHEN DISASSEMBLING ALUMINUM EXTRUSION, TIGHTEN ALL SETSCREWS AND LOCKS TO PREVENT LOSS DURING SHIPPING**

866.652.2100

Item	Qty.	Description
18	1	36" h Vertical Extrusion
19	1	36" h Vertical Extrusion w/ Door Hinges
20	1	36" h Vertical Extrusion w/ Door Stop
21	1	36" h Vertical Extrusion
22	4	26" w Horizontal Extrusion
23	4	18" w Horizontal Extrusion

Steps:

- 1) Attach lower horizontal bars between vertical extrusions.
- 2) Place infill panels and attach door where indicated.
- 3) Attach upper horizontal bars between vertical extrusions and atop infills and door.
- 4) Velcro shelf supports to inside of assembled base.
- 5) Set internal shelf on top of supports.

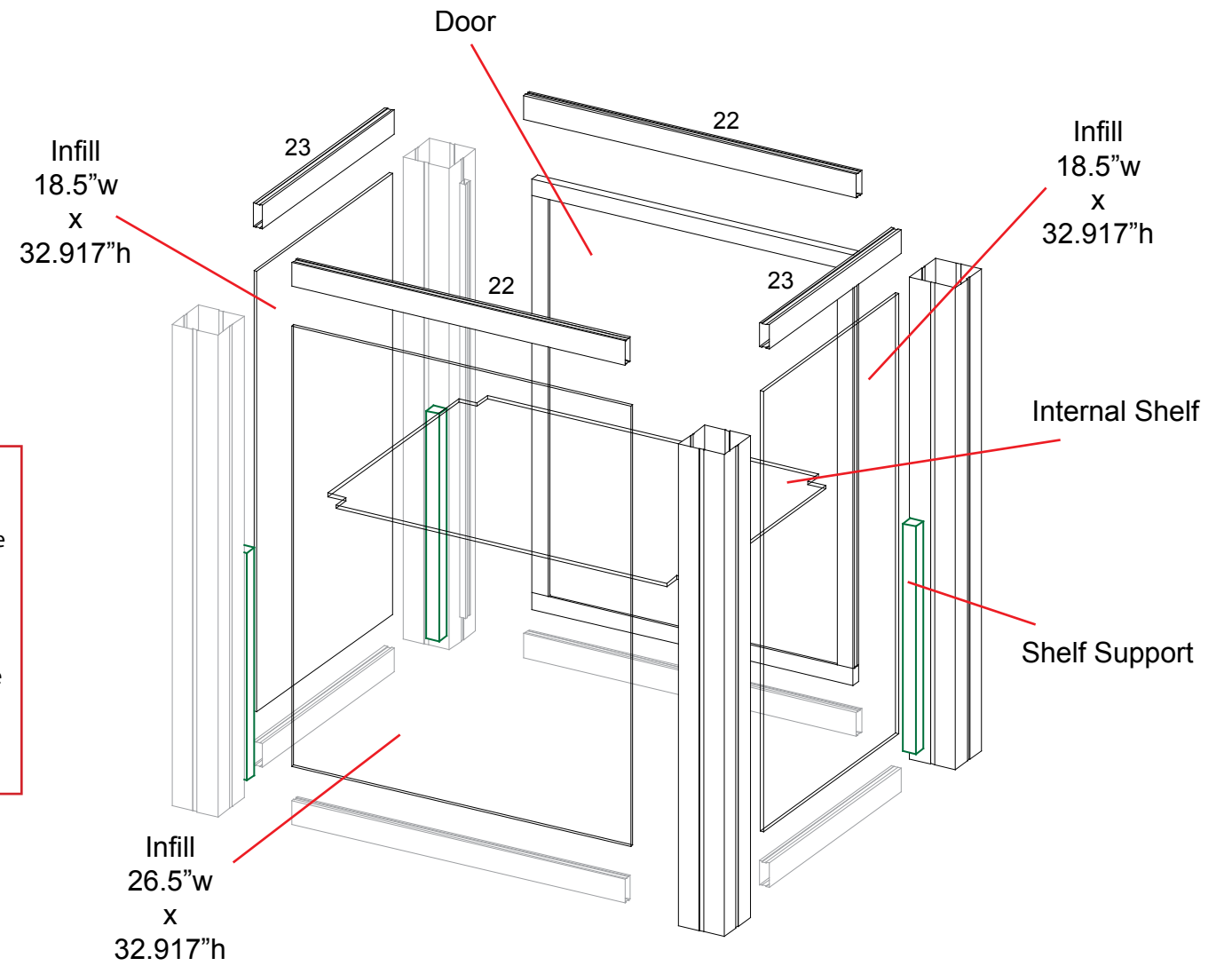
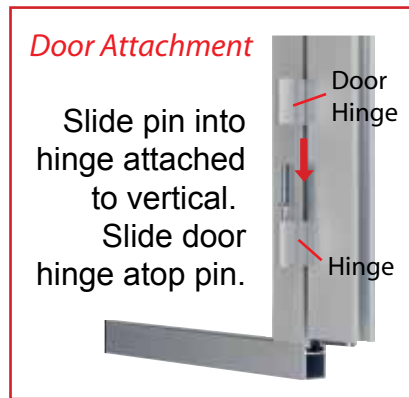
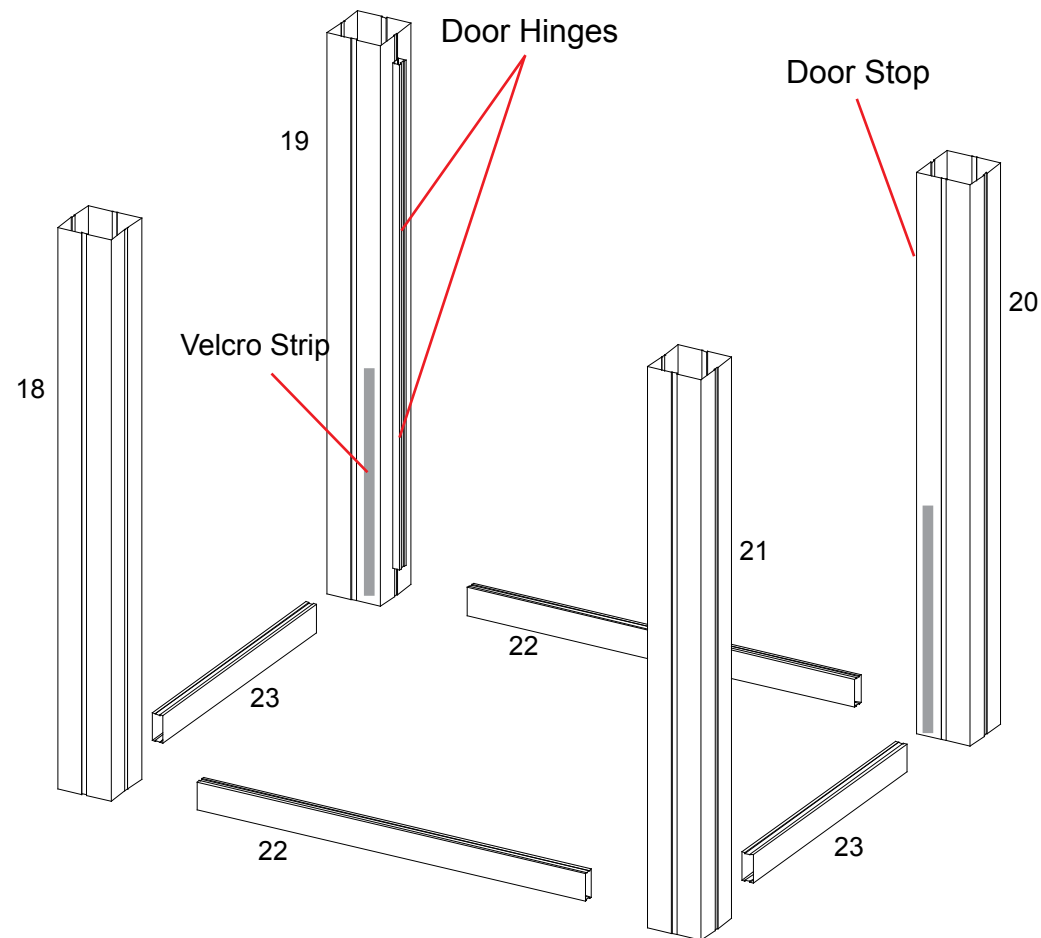

**WHEN DISASSEMBLING ALUMINUM EXTRUSION, TIGHTEN ALL SETSCREWS AND LOCKS TO PREVENT LOSS DURING SHIPPING**

866.652.2100

Item	Qty.	Description
24	1	36" h Vertical Extrusion
25	1	36" h Vertical Extrusion
26	3	12" w Horizontal Extrusion

**Graphic Attachment**

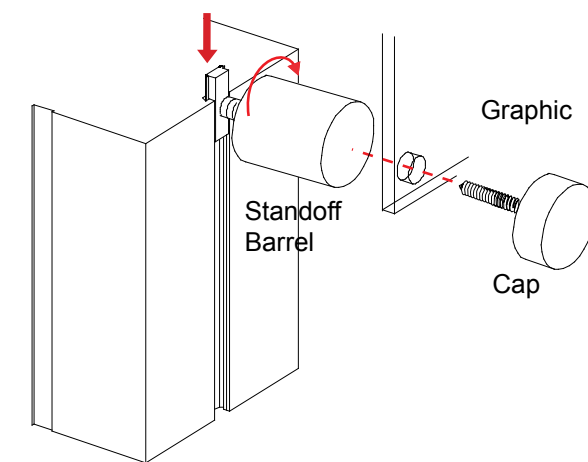

Slide connector on back of standoff barrels into groove of extrusion and twist to secure in place. Secure graphic to standoffs using screw caps.

**Steps:**

- 1) Connect vertical extrusions [24 and 25] to assembled pedestal using horizontal extrusions [26].
- 2) Attach pin to vertical extrusion [21].
- 3) Set lower tier counter atop extrusions [24 and 25] and on top of pin.
- 4) Set counter top on assembled pedestal.
- 5) Attach graphic to assembled pedestal using standoffs.

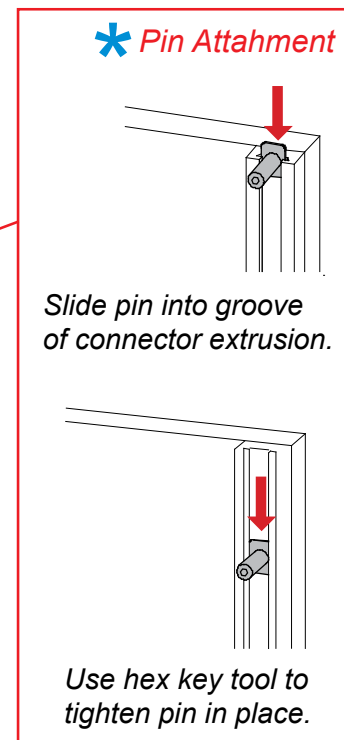
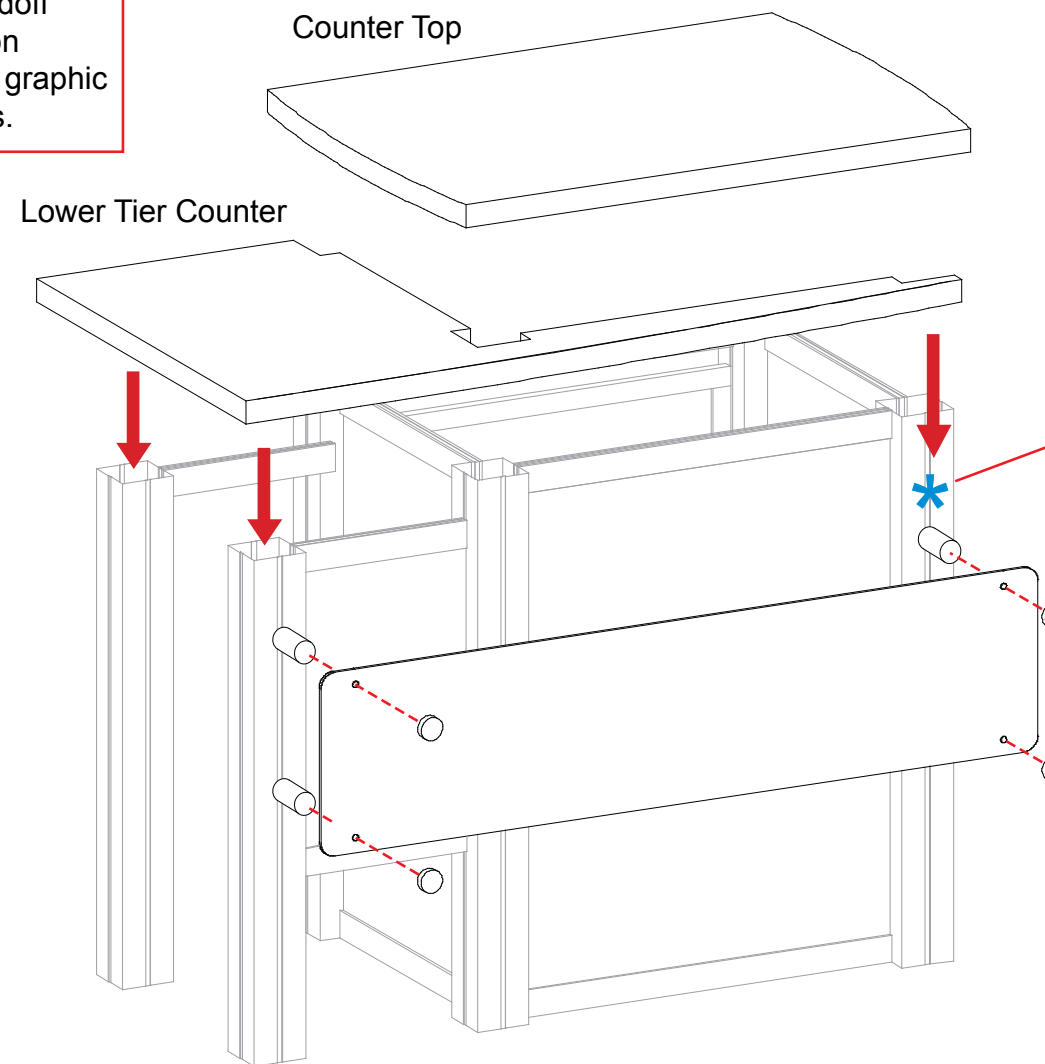
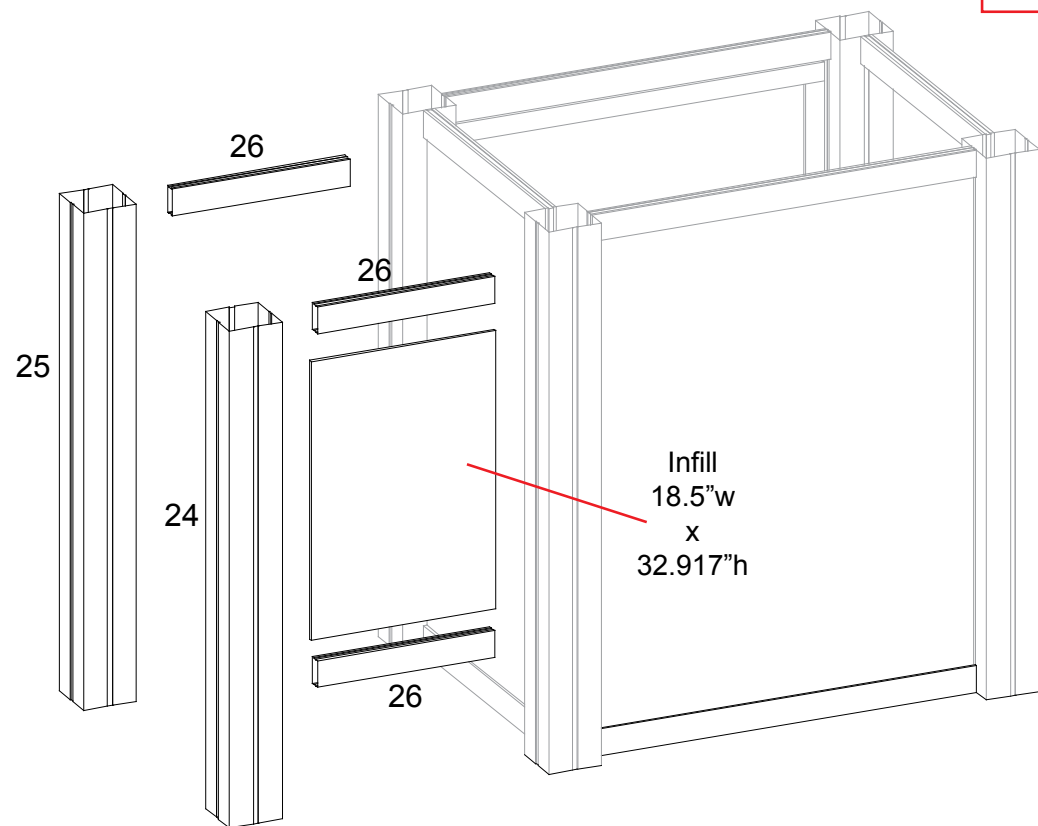

**WHEN DISASSEMBLING ALUMINUM EXTRUSION, TIGHTEN ALL SETSCREWS AND LOCKS TO PREVENT LOSS DURING SHIPPING**

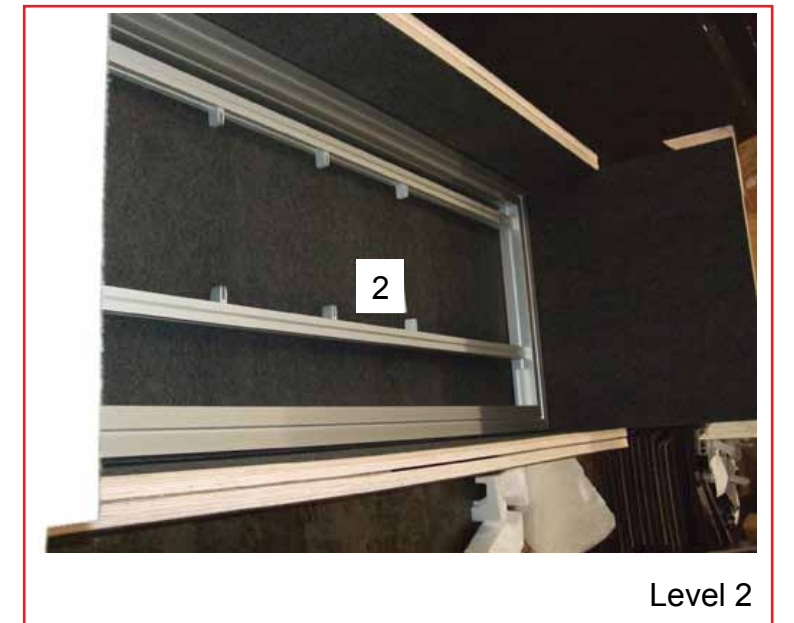
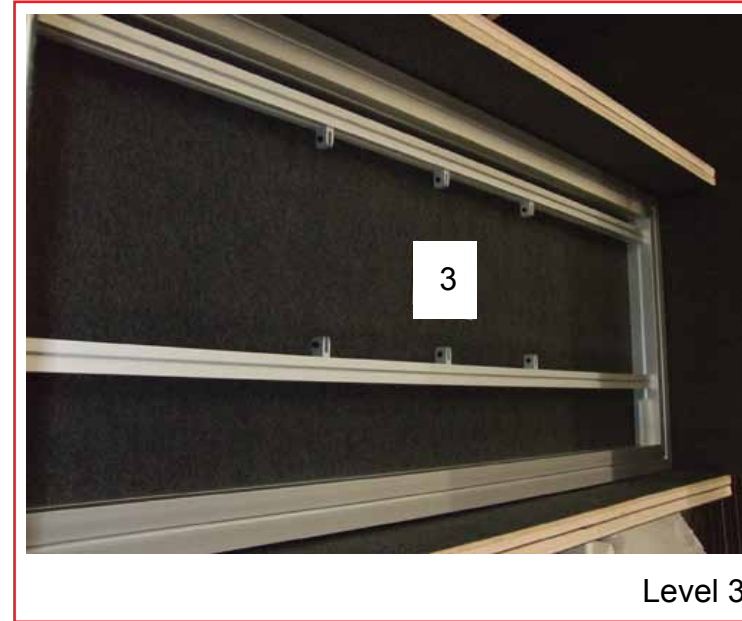
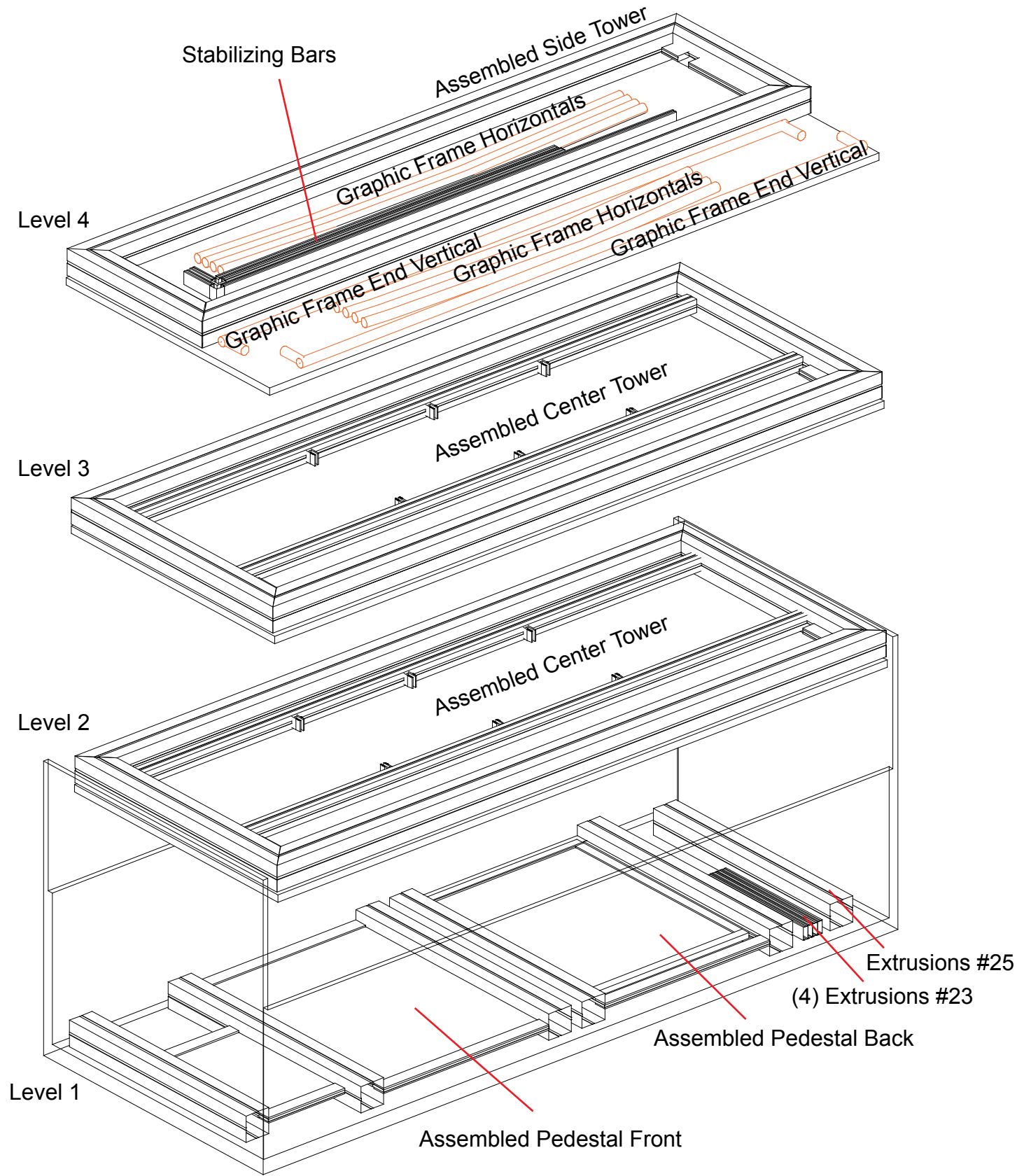

**WHEN DISASSEMBLING ALUMINUM EXTRUSION, TIGHTEN ALL SETSCREWS AND LOCKS TO PREVENT LOSS DURING SHIPPING**

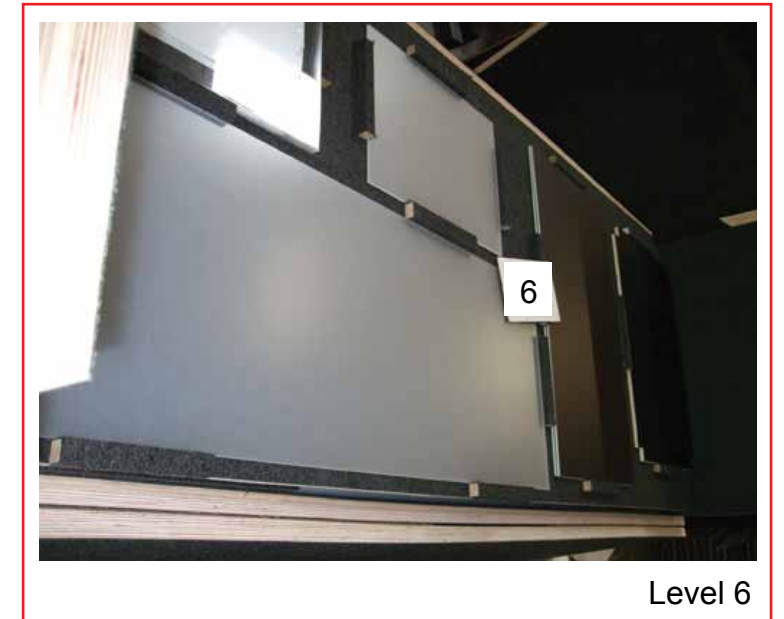
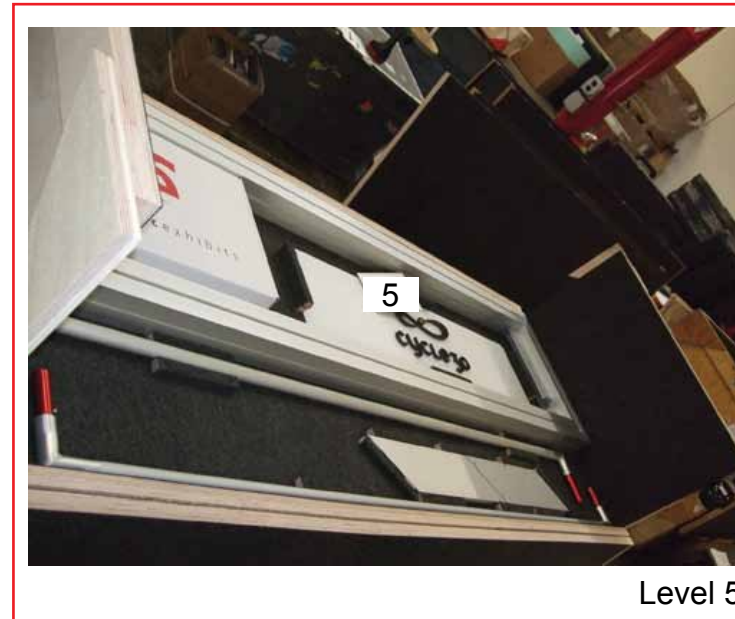
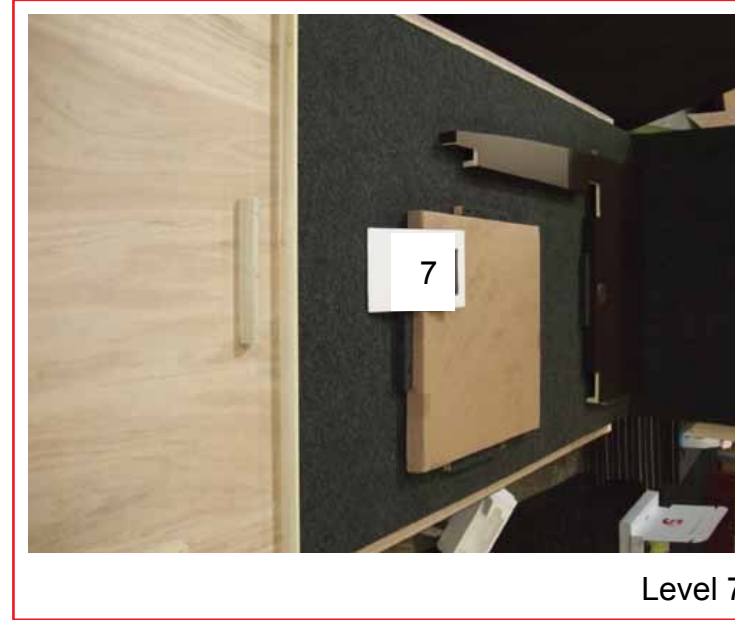
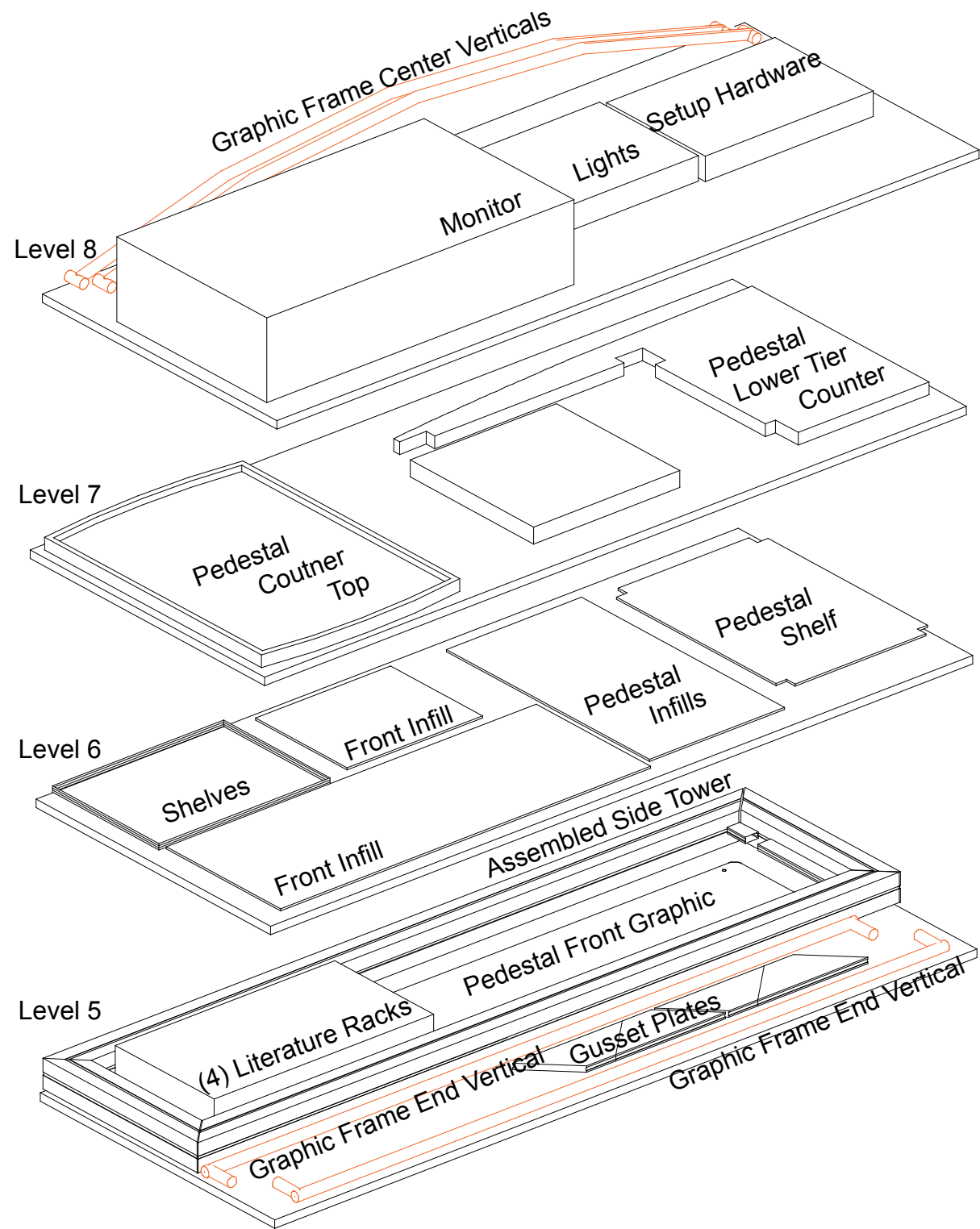

WHEN DISASSEMBLING ALUMINUM EXTRUSION, TIGHTEN ALL SETSCREWS AND LOCKS TO PREVENT LOSS DURING SHIPPING